



ALL WEATHER

ARCHITECTURAL ALUMINUM

ALL WEATHER ARCHITECTURAL ALUMINUM

777 ALDRIDGE ROAD

VACAVILLE, CA 95688

PHONE: (707) 452-1600

FAX: (707) 452-1616

www.allweatheraa.com

SELECT DESIRED FINISH:

- CLEAR ANODIZED CLASS
- BRONZE ANODIZED CLASS
- STANDARD WHITE
- CUSTOM ANODIZED
(SPECIFY CUSTOM COLOR _____)
- CUSTOM 70% KYNAR PAINT
(SPECIFY CUSTOM COLOR _____)

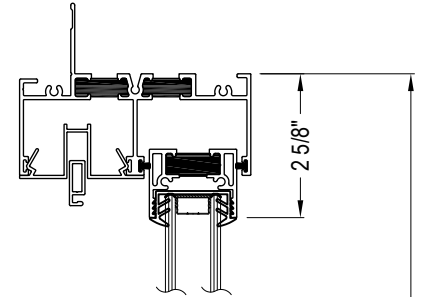
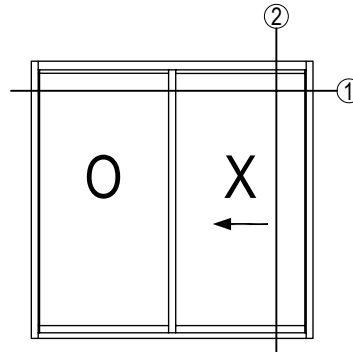

EXTERIOR

INTERIOR

NET HEIGHT

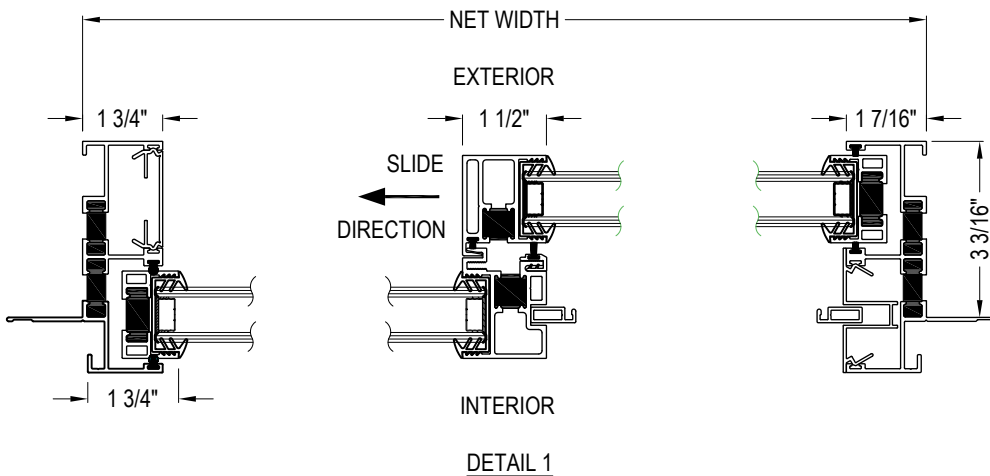

DETAIL 1

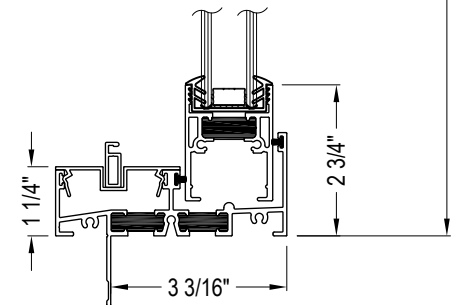

DETAIL 2

FEATURES

- 3 1/8" FRAMES WITH MITERED CORNERS
- MAXIMUM OF 28 SQUARE FEET TOTAL OR 180 LBS
- THERMALLY BROKEN FRAME - POUR AND DEBRIDGE SYSTEM
- EXTRUDED ALUMINUM SCREEN

NOTES:

1. INSTALLATION TO BE COMPLETED IN ACCORDANCE WITH MANUFACTURER'S SPECIFICATIONS.
2. DO NOT SCALE DRAWING.
3. THIS DRAWING IS INTENDED FOR USE BY ARCHITECTS, ENGINEERS, CONTRACTORS, CONSULTANTS AND DESIGN PROFESSIONALS FOR PLANNING PURPOSES ONLY. THIS DRAWING MAY NOT BE USED FOR CONSTRUCTION.
4. ALL INFORMATION CONTAINED HEREIN WAS CURRENT AT THE TIME OF DEVELOPMENT BUT MUST BE REVIEWED AND APPROVED BY THE PRODUCT MANUFACTURER TO BE CONSIDERED ACCURATE.
5. CONTRACTOR'S NOTE: FOR PRODUCT AND COMPANY INFORMATION VISIT www.CADdetails.com/info AND ENTER REFERENCE NUMBER 4461-148.

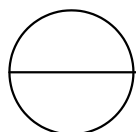

SERIES 6200 WINDOWS

NAIL ON WITH OPTIONAL BLOCK FRAME - XO SLIDING 3 1/8" THERMALLY OPTIMIZED WINDOW