



INSTALLATION INSTRUCTIONS

SERIES 8100 | MULTI SLIDE DOOR SYSTEM



ALL WEATHERTM
ARCHITECTURAL ALUMINUM



INSTALLATION QUALITY CONTROL

Performing specific quality control procedures is a critical part of completing any All Weather installation. We recommend the installer fill out the quality control sheet and file as a record of correct and complete installation.

Customer: _____ Phone: _____

Address: _____

Installer: _____ Phone: _____

Where product was purchased: _____

Dealer Contact: _____

RECEIVING AND INSPECTING OF PRODUCT

- Product was checked upon delivery at job site for correctness and was received as ordered
- Product was checked and free of damage
- Any damage or incorrectness was reported immediately to All Weather or the dealer where the product was purchased
- Product was stored in a dry safe place where it could avoid damage
- Hardware box contents were checked

PRE-INSTALLATION

- General Contractor or homeowner has been consulted prior to installation of product
- Opening is configured correctly, and any squaring or level issues have been identified
- Appropriate size header has been verified for use in opening
- Required - Sill pan with Rear Leg (Back Dam) has been fabricated from appropriate material and located correctly in the depth of the opening
- Overhangs and other necessary design elements are present where appropriate
- Local codes and practices are being adhered to regarding installation of product
- Problems pertaining to existing windows, doors and/or rough openings have been reported to responsible party and have been resolved and documented
- All safety issues related to unsafe site conditions and hazardous materials have been properly addressed and resolved



INSTALLATION

- All installation materials used have been checked for compatibility
- Weather resistant barrier and flashing were coordinated with contractor or authority on site
- If Swing Series, correct orientation of system has been identified. Inswing or Outswing.
- If Slider Series (including Stacking and Pocketing Series), location of operable and non-operable panels has been checked
- If Bi-Fold Series, panel sequence has been checked from right to left, as seen from exterior
- Frame has been sealed and joined at all points indicated in instructions
- Opening checked for correct dimensions
- Frame is installed at correct depth within the opening
- Frame has been installed square, level and plumb
- Plastic shims were utilized under sill when required
- Jambs were shimmed to prevent rolling
- Head track installed with the appropriate crown over width of frame
- Installation holes prepared correctly
- Sealant was applied to sill installation holes prior to inserting screws & top of screw heads once applied
- Correct fastener placement has been followed as directed by manufacturer
- Proper operation and adjustment has been achieved
- Product was installed as directed by the Manufacturer

FINAL CHECK OF INSTALLATION

- Frame has been checked for level, square and plumb
- All horizontal and vertical adjustments have been made so that proper reveals are present and product is operating as designed
- Weep holes have been checked and free of obstruction and debris
- All trash has been discarded
- All hardware has been installed correctly and checked for proper operation
- Product has been closed and locked and recommended to not be used as thoroughfare by other trades.
- Product is protected from damage
- Final inspection of weather proofing and operation has been performed
- Job has been turned over to contractor or other responsible party with approval
- Other _____

IMPORTANT

All Weather recommends that installers return to site and perform a final check of installation. **Namely that the header has not sagged under structure settlement and/or weight and necessary adjustments have been made prior to installation of exterior siding/stucco and interior finishes.**

Where applicable, each of the items checked above have been properly reviewed, verified and completed as part of my field quality control check prior to turning over the job to the responsible party/approving authority.

Installer's Signature: _____ Date: _____



THANK YOU FOR PURCHASING FROM ALL WEATHER.

ALL WEATHER INSTALLATION AND WARRANTY INFORMATION

The following instructions are to be used for All Weather assembly and installation.

Limited warranty varies based on job type. A copy of the limited warranty and the comprehensive care and maintenance guide can be found at www.allweatheraa.com.

Failure to follow factory assembly, installation and maintenance instructions will void the manufacturer's limited warranty. All visible defects must be reported before installation and finishing.

These instructions are the property of All Weather Architectural Aluminum and may not be duplicated, altered or distributed for any purpose whatsoever without the express written permission of All Weather.



THE MOST IMPORTANT CRITERIA FOR A SUCCESSFUL JOB ARE A SQUARE OPENING, A RIGID HEAD AND A CLEAN TRACK.

It is recommended that All Weather doors are installed with at least two people; one person handling the door panels and the other attaching and adjusting hardware.

The installation of your door system requires that the sill, head and jambs are perfectly straight and square. It is recommended that the head be installed with a slight bow upward (amount specified in installation instructions). The sill should be installed flat and straight, ensuring that there is no upward bowing. The frame should be checked for square and twist.

Assembly screws are provided by All Weather. Be sure to clean any metal shavings from the head track to avoid damage to the rollers.

Ensuring your frame is square, plumb, and attached properly to an adequate header will alleviate problems in the future.

Installation of flashing to ensure a proper water seal is the responsibility of the installer. Local codes and building practices should be applied.

All Weather doors require sill pans with rear leg (back dam) and recommends Consultation with a water proofing consultant for an adequate drainage system.

***IMPORTANT NOTICE* – READ PRIOR TO INSTALLATION.**











An All Weather system is a specialty product that you cannot assume to be a standard installation of a typical door or window.

All Weather products should be installed with overhead protection to prevent the effects of sheeting water from above.

We recommend that a professional waterproofing consultant be used to properly integrate our products into the weather barrier of the wall structure.







PROVIDED ASSEMBLY FASTENERS & PARTS

PART	PICTURE	DESCRIPTION	PURPOSE
1		#10-12 x 3" Square Drive Pan Head Grade 18-8 Type A Point Stainless Steel Sheet Metal Screw	To secure the keeper onto the door jamb and building frame through 4 slotted holes.
2		#8-15 x 1-1/2" Square Drive Pan Head Grade 18-8 Type A Point Stainless Steel Sheet Metal Screw	To fasten the door frame components together. 8 per track will be needed.
3		#10-16 x 1" Square Flat Head Crypton Finish 410 Stainless Steel Self-Drilling Screw	To fasten the fixed panels to the frame and to install false jambs.
4		#8 x 3/8" Square Drive Pan Head #2 Point 410 Stainless Steel Self-Drilling Screw	To fasten the nail-fin to the head and jambs of the frame.
5*		#10 x 3/4" Square Drive Flat Head 410 SS Self-Drilling Screw (*for panel collector option or staggered tracks)	To fasten panel collectors to intermediate panels, to fasten track end caps to track faces.
6		.18" x 12" Black Rigid PVC Track Clip	To connect multiple Head, Sill, and Jamb Assemblies together via the frame connecting grooves.
7		3mm x 30mm Spring Roll Pin	For splicing: to connect multiple head and sill Assemblies together via screw holes.
8		Black PLA Roller Track Connector	For splicing: to connect multiple Head and Sill assemblies together via the frame roller track grooves.
9		Aluminum Splicing Plate (sheet metal)	For splicing: to reinforce splice joint
10		Nail-Fin Corner Adapter	To connect the nail fins on the jambs to the nail-fin on the head to allow for a better seal on the exterior corners.



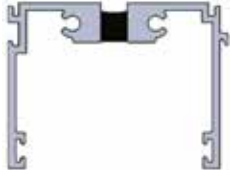
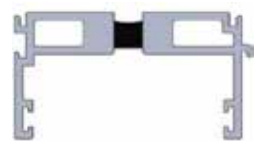



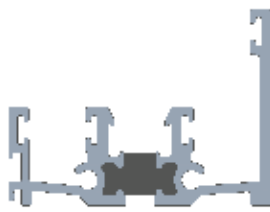
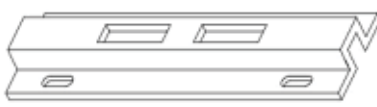

PROVIDED ASSEMBLY FASTENERS & PARTS

PART	PICTURE	DESCRIPTION	PURPOSE
11A		Head Nail-Fin	To attach the frame to the rough opening of the building on the top.
11B		Left Jamb Nail-Fin (Top end shown in diagram)	To attach the frame to the rough opening of the building on the left side.
11C		Right Jamb Nail-Fin (Top end shown in diagram)	To attach the frame to the rough opening of the building on the right side.
12		Head Track	To guide sliding door, top member of door frame.
13		Jamb Track	Frame member. To collect panels and provide a seal for panels when in the closed position. The keeper will be mounted on the inside of the jamb.
14A		Sill Track	Frame sill member. To provide a weight bearing member and track for the panel rollers to travel on.
14B		Flush Set Sill Track	Frame sill member option. To provide a weight bearing member and track for rollers to travel on. Designed to sit flush with flooring.





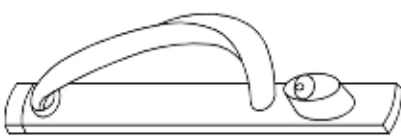

PROVIDED ASSEMBLY FASTENERS & PARTS

PART	PICTURE	DESCRIPTION	PURPOSE
14C		2" Water Leg Sill	Frame sill member option. Serves as the interior track for the standard 3/4" sill track option (Part #14c) to provide better water performance. Does not require any additional nor different installation step from the standard sill (Part #14a).
15		Keeper	To provide the panel hooks on panels channels to lock into to keep the panel secured into the frame.
16		1.8" x 1.6" Trim Cap	To cover and protect the track pockets on the Jambs that will not be used by the panels.
17		.4" x .6" Threshold	To cover and protect the track pockets on the sills that will not be used by the panels.
18*		Panel Collector (*optional add-on)	Designed to not allow panels to bypass one another while opening sliding doors.
19*		Head Track End Cap (*for staggered track doors only)	Designed for aesthetic purposes to cover the exposed head track faces in the location the staggered tracks terminate.
20*		Sill Track End Cap (*for staggered track doors only)	Designed for aesthetic purposes to cover the exposed sill track faces in the location the staggered tracks terminate.
21A		Pull Handle Keyed	To provide a way to open and close a panel easily that also allows for the panels to be locked/unlocked by a key. The latches can be engaged/disengaged by rotating the thumbturn.

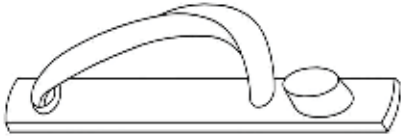
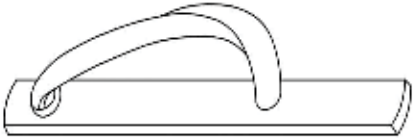

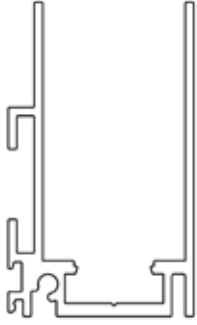
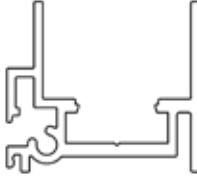
PROVIDED ASSEMBLY FASTENERS & PARTS

PART	PICTURE	DESCRIPTION	PURPOSE
21B		Pull Handle with Thumbturn	To provide a way to open and close a panel easily. The latches can be engaged/ disengaged by rotating the thumbturn.
21C		Dummy Pull Handle	To provide a way to open and close a panel easily.
22		#6-20 x 3/8" Phillips Drive Flat Head Zinc Finish #2 Point Steel Self-Drilling Screw	For splicing: to fasten splicing sheet metal plates to head and sill tracks.
23A		Brio Head Track	Adapter track for Brio Screen
23B		Brio Sill & Locking Jamb Track	Adapter track for Brio Screen
23C		Brio Jamb Track	Adapter track for Brio Screen



Note: Opening should be flashed with the appropriate flashing material to meet industry standards. Please refer to Federal Specification UU-B-790a and AAMA 2400-02.

Disclaimer: Each installation job has its unique set of challenges and circumstances. Because of that, the provided set of installation instructions for All Weather Architectural Aluminum products is meant only to serve as a set of standardized guidelines and NOT necessarily a strict manual to follow regardless of situation.

As a professional, it is incumbent upon you and your team to identify instances that do not align with the Installation instruction requirements. All installations must comply with AAMA specifications.

Accordingly, All Weather does not assume responsibility, and disclaims liability for damage, loss, or expense arising from improper use or application of these installation instructions.

FRAME ASSEMBLY/INSTALLATION

1. Verify that the rough opening is the correct size to assure the door will fit in the opening.
2. Check to ensure that the floor where the door will be installed is level. If the floor is not level and varies more than $\frac{1}{16}$ " per foot or a total of $\frac{1}{4}$ " over the entire width of the opening, correct the floor prior to installation.
3. Remove the frame components from its packaging and lay it out in front of the opening. Note that the notches for a nail-fin goes toward the exterior (Figures 1,2 & 3).
4. For doors with multiple tracks, attach adjacent heads, jambs, and sills (Part #12, #13, #14a/b/c) using track clips (Part #6). Figures 1, 2 & 3 from step 3 show the junction of standard, flush set and 2" water leg sills via track clips. Track clips can be pressed or hammered into place.
5. For Brio screen installation, see Appendix B, C & D.

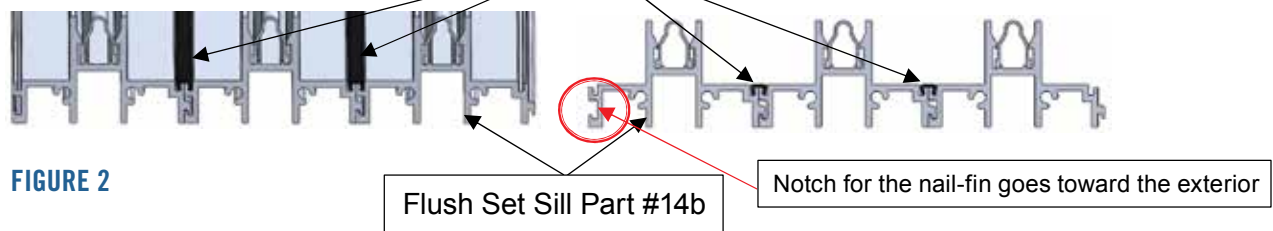
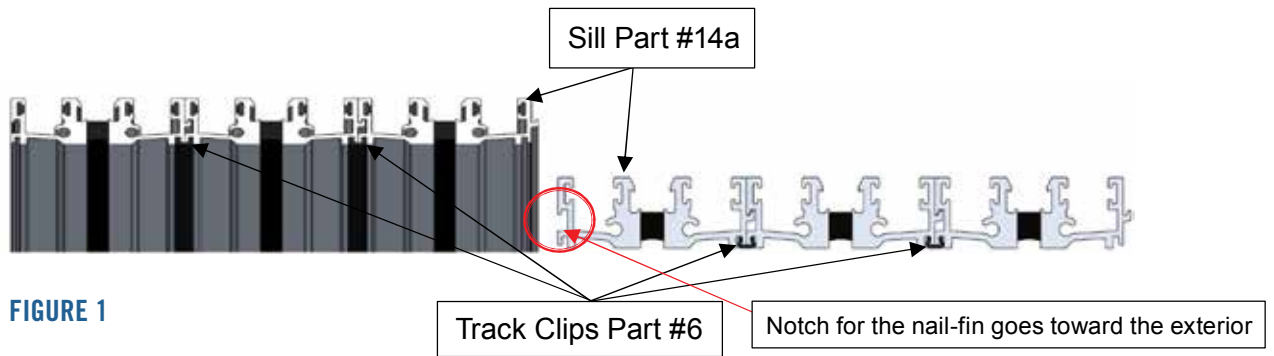

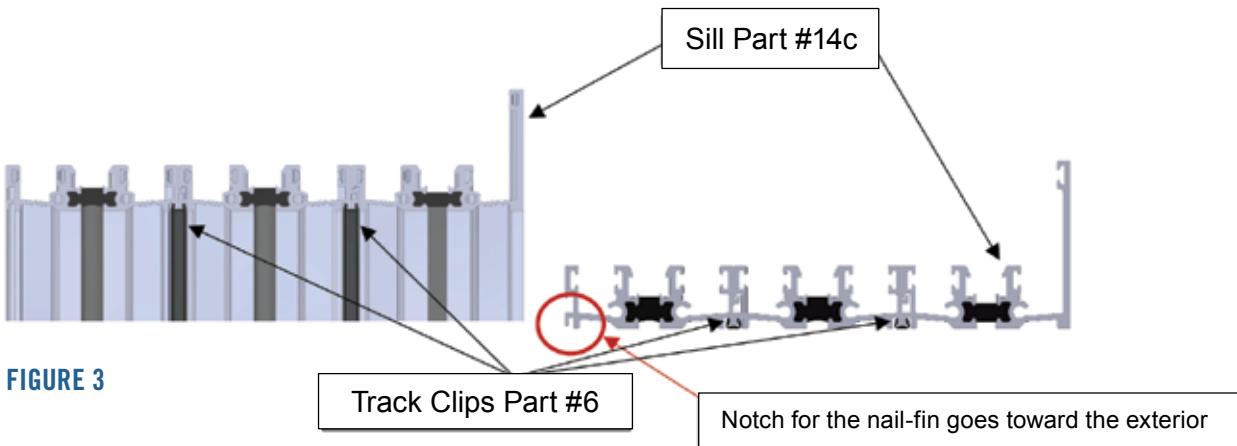

FIGURE 3

1. Splicing is required for doors wider than extrusion stock length. To splice the sill (and Flush Set Sill), insert roll pins (Part #7) halfway into screw channels as shown in Figure 1. Coat track connectors (Part #8) in sealant (Sealant should conform to AAMA 802.3-16 and 803.3-16) and slide halfway into the roller track. Coat the entire cross-sectional face with sealant as shown in Figure 2 and join the components by tapping one track into the other. Lastly, fasten Splicing Plate (Part #9) over the junction using (Part #22) screws. Screw in the location of the thermal dividers (shown in Figure 2). Splicing plate is not required for a flush set sill. Before screwing the plate to the sill, use a $\frac{3}{8}$ " countersink bit to create countersinks for the top of the flat head screws to sit flush with the plate.

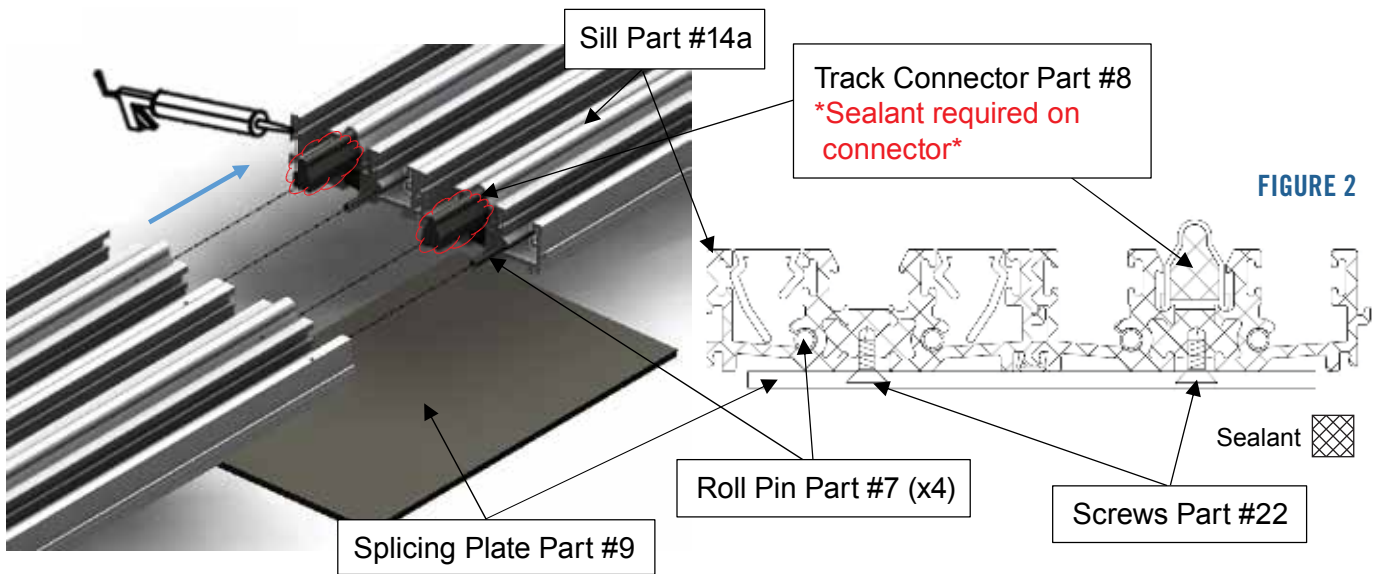

FIGURE 2

FIGURE 1



2. To splice the head (Figure 1), insert roll pins (Part #7) into the head screw channels. Coat the entire cross section in sealant as shown in Figure 2, join components, and ensure track clip (Part #6) crosses over the splice (if multiple track door). Lastly, attach splicing plate (Part #9) over the junction using (Part #22) screws at the thermal breaks. Countersink the plate for the screws beforehand.

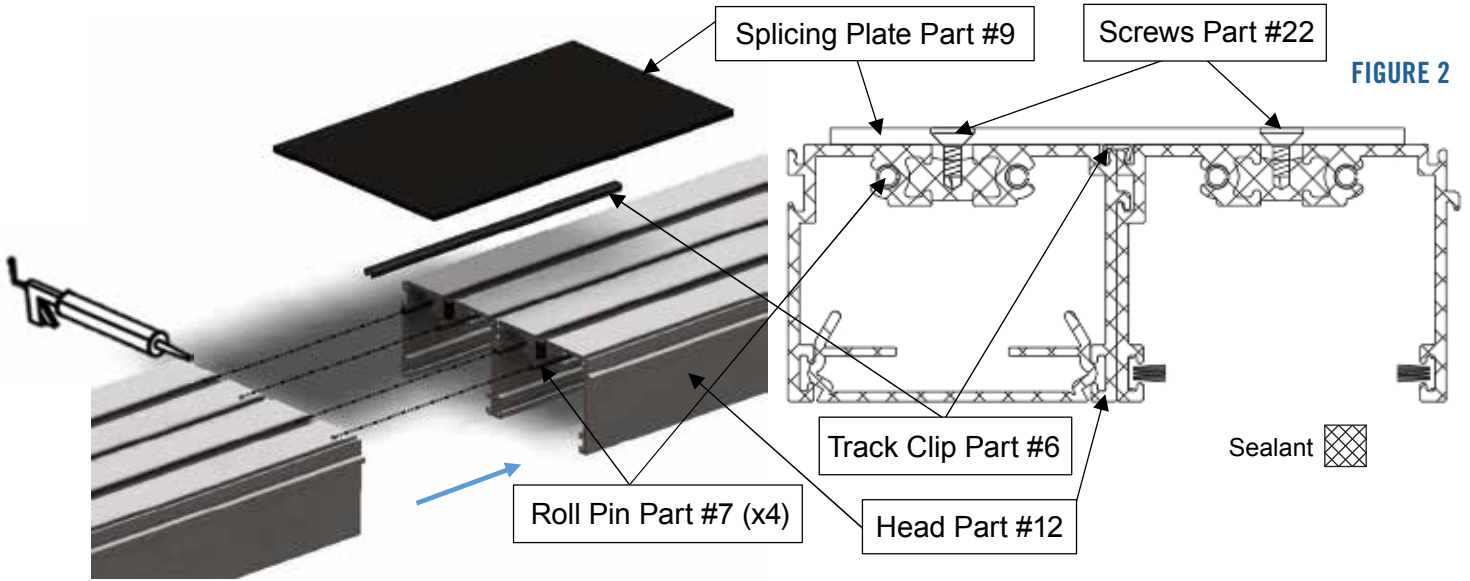

FIGURE 1

FIGURE 2



3. It is recommended to remove the pre-installed trim caps (Part #16) from head and jamb tracks before assembling the frame. Prepare frame by applying compatible sealant around the perimeter of both ends of the frame head (Part #12) and sill (Part #14a, 14b for Flush Set Sill). Use the screws (Part #2) provided in the hardware box (Use sealant to lubricate screws) and assemble the frame as shown in Figures 1, 2, & 3.

Note: Remove Trim Caps (Part #16) from head and jamb tracks before assembling frame

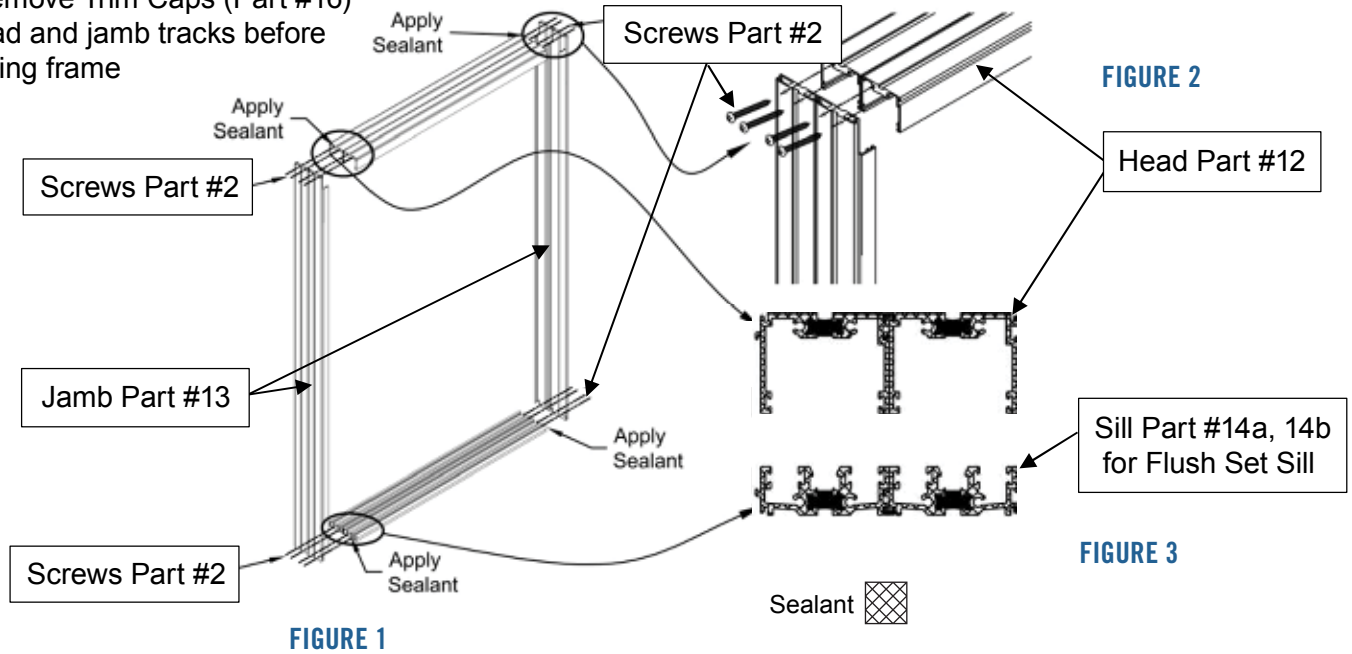

4. Next, connect the head nail-fin (Part #11a) to the head of the frame (head nail-fin does not have shaved hooks). To do this, first apply a continuous bead of sealant to the nail-fin in the pocket it will contact the head (Figure 1). The head nail-fin should extend slightly beyond the head track on either side and fit into the pocket created by the jambs (Figure 2). Pre-drilled holes should line up on the head and head nail-fin.

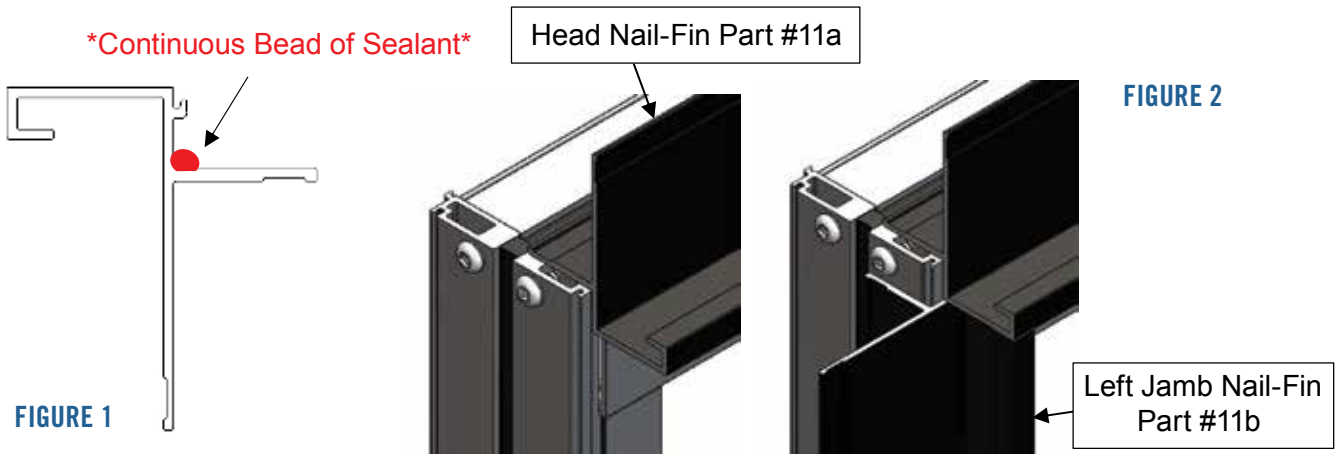



5. Fasten the head nail-fin using screws (Part #4) as shown in Figure 1. Screw at the locations of the pre-drilled holes. Repeat process for left and right jamb nail-fins. Note left and right nail-fins must be on correct sides to fit on the frame properly.

Note: Line up pre-drilled holes on nail-fins and head/jamb

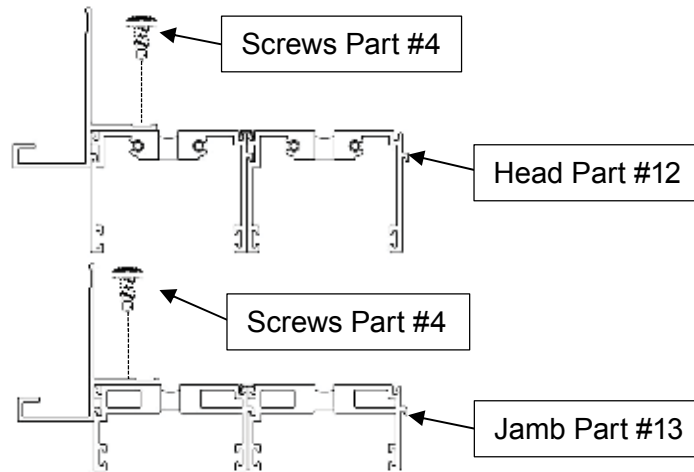

FIGURE 1

6. Prepare rough opening by checking diagonal dimension of opening to verify square and apply water resistant barrier as shown in Figure 1. Use steps A through D for applying water resistant barrier.
- 12" Sill Wrap (3" wrapped into opening); Overlaps where sill Self-Adhering Sheet Membrane (SASM) will be by 1" (Self-adhered flashing is optional)
 - 12" Jamb SASM (3" wrapped into opening), overlaps Sill SASM by 1" and runs 2" beyond header opening
 - 6" Header Wrap (3" wrapped into opening), overlaps jamb SASM by 1"
 - Sill pan is recommended on all door installs, with the exception of frames with a flush set sill (Part #14b). Consult step 15 for details on securing the sill pan to the opening.

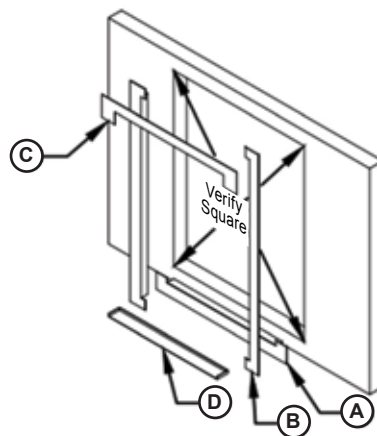

FIGURE 1



7. Clean the exterior of the frame (including the nail-fin) with a moist rag (wetted with water) so that the frame and nail-fin are free from dirt and other construction debris and dry it with a dry clean rag or allow it to air dry.
8. Make sure that each corner joint of the frame has sufficient sealant. Apply sealant to the corner joints as necessary to ensure a watertight seal as shown in Figure 1.

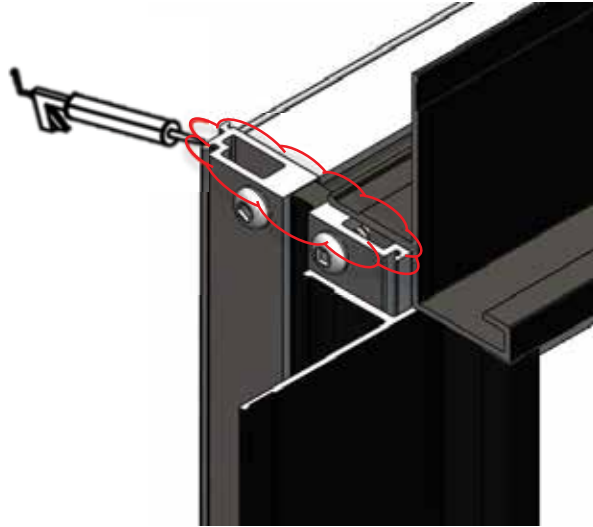

FIGURE 1

9. Apply sealant to the backside of the 2 Nail-Fin Corner Adapters (Part #10) and install the brackets at upper corners of the frame as shown in Figure 1.

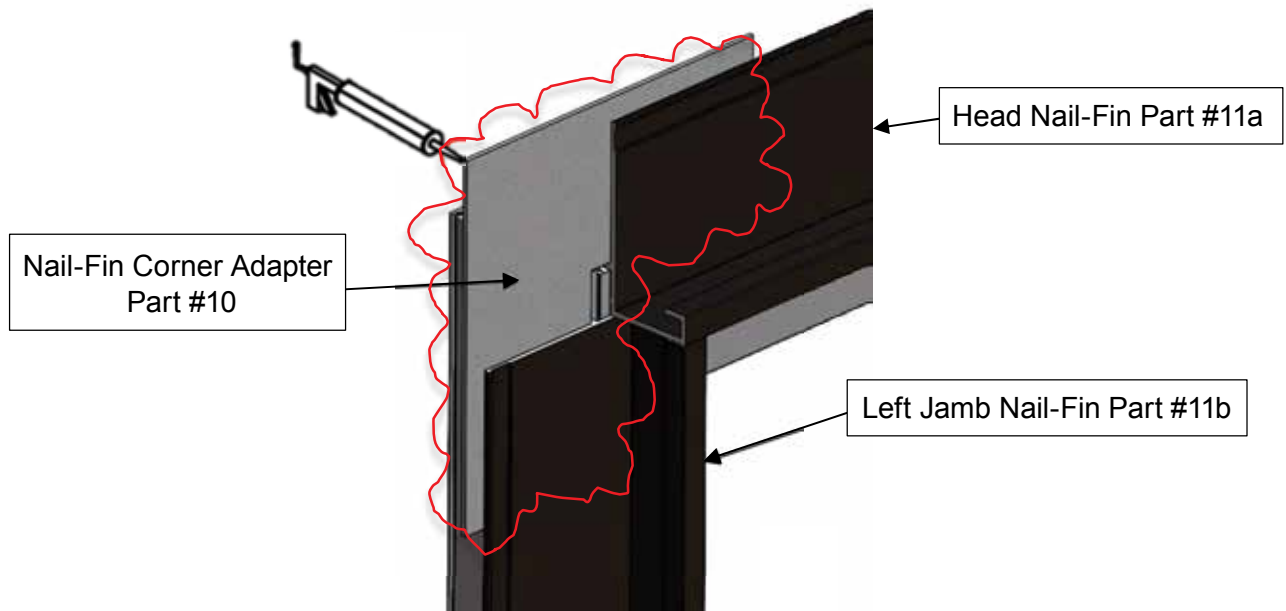
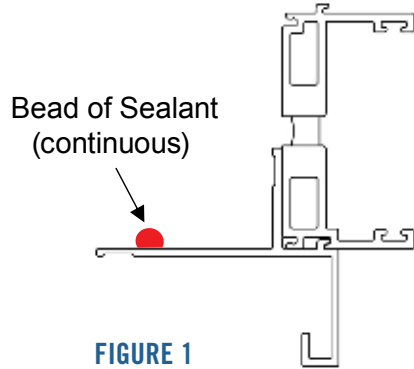

FIGURE 1



10. Apply a continuous bead of sealant on the nail-fins (Part #11a, 11b, 11c, interior side as shown in Figure 1) around the perimeter of the head (Part #12) and jambs (Part #13) of the frame as shown in Figure 2, including the nail-fin corner adapter (Part #10). Sealant should conform to AAMA 802.3-16 and 803.3-16.



11. For frames with a standard sill (Part # 14a), use step 15 for installing frame. For a flush set sill installation (Part #14b), consult step 16. Apply several continuous beads of sealant across the bottom of the sill pan (enough to cover the entire contact area between sill pan and opening), and shim as needed under the sill pan to ensure level. Insert sill pan into the opening. Next, apply beads of sealant to the underside of the frame's sill, incrementally spaced between the weep channels as shown in Figures 1 & 2. (Sealant should conform to AAMA 802.3-16 and 803.3-16). Insert the frame into the opening as shown in Figures 2 & 3. Manipulate frame to achieve proper alignment. Shim around jambs and head, as necessary. Make sure the exterior and weeps are not covered with sealant to allow water in the tracks to weep out. After frame is installed, seal all four corners with sealant as shown in Figure 3.

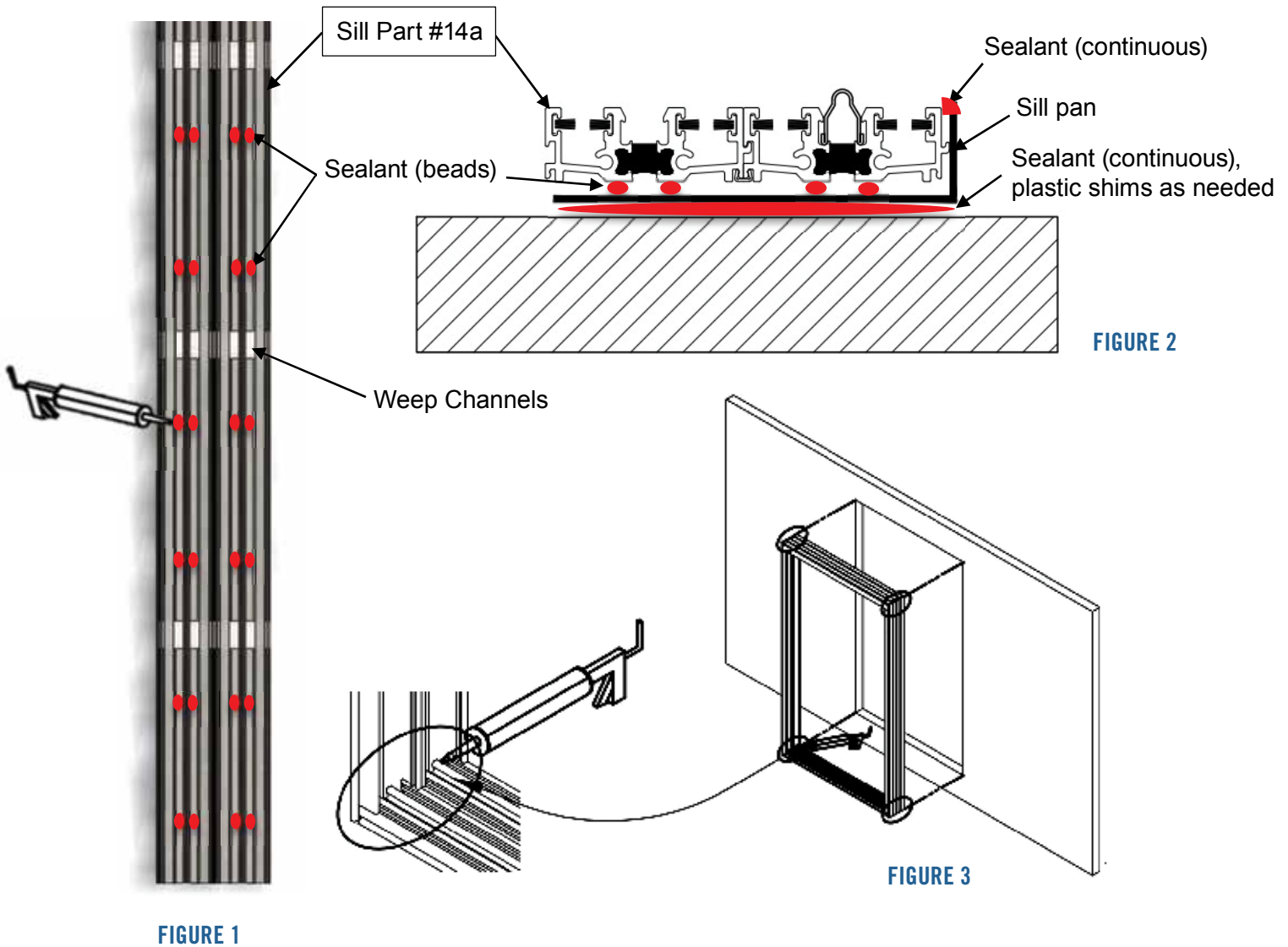

12. For a frame with flush set sill (Part#14b), a sill pan/sealant is not necessary under the sill. Insert frame into the rough opening and shim as needed under the flush set sill to ensure level as shown in Figure 1. Install screws where there are shims. After the frame is installed, seal all four corners with sealant as shown in Figure 2.

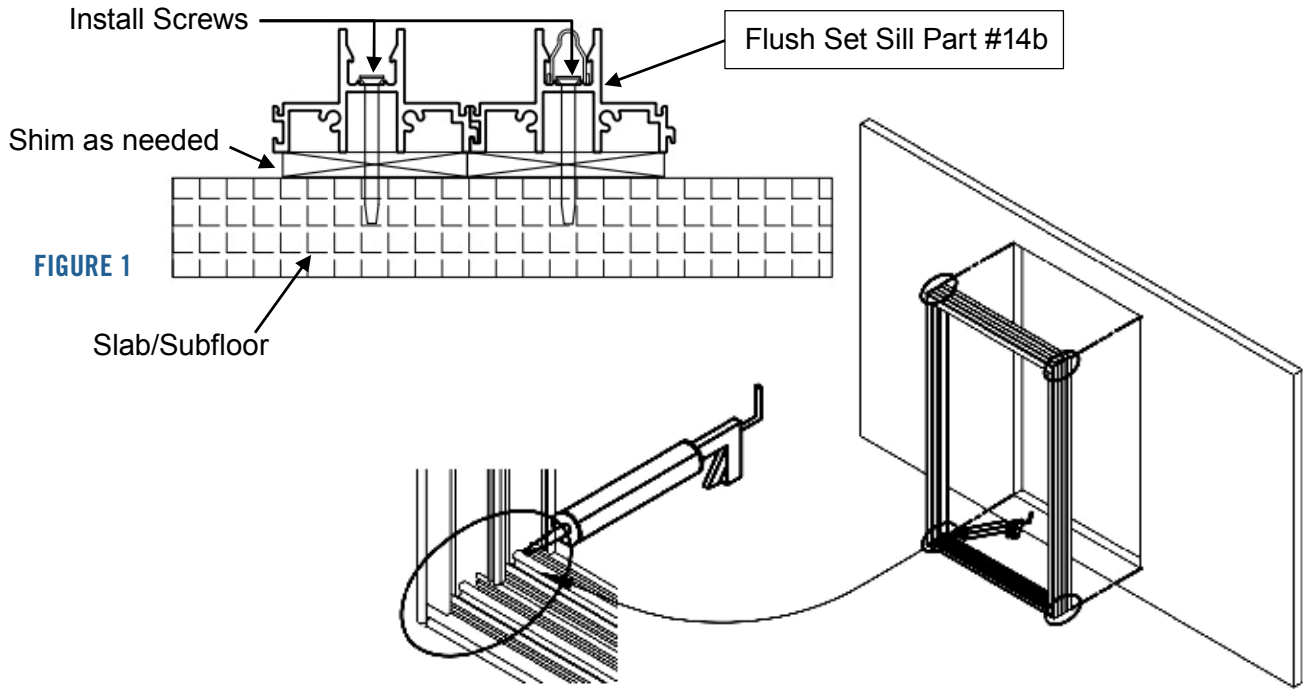

FIGURE 2

13. Secure door frame to the opening using appropriate fasteners. Install screws on the linear fin indicator as shown in Figure 1; spacing to be as shown in Figure 2 where $A = 12"$ and $B = 3"$. Cross measure and use shims as necessary to adjust the door frame so that the door frame is plumb, level and square. Seal all fasteners with compatible sealant.

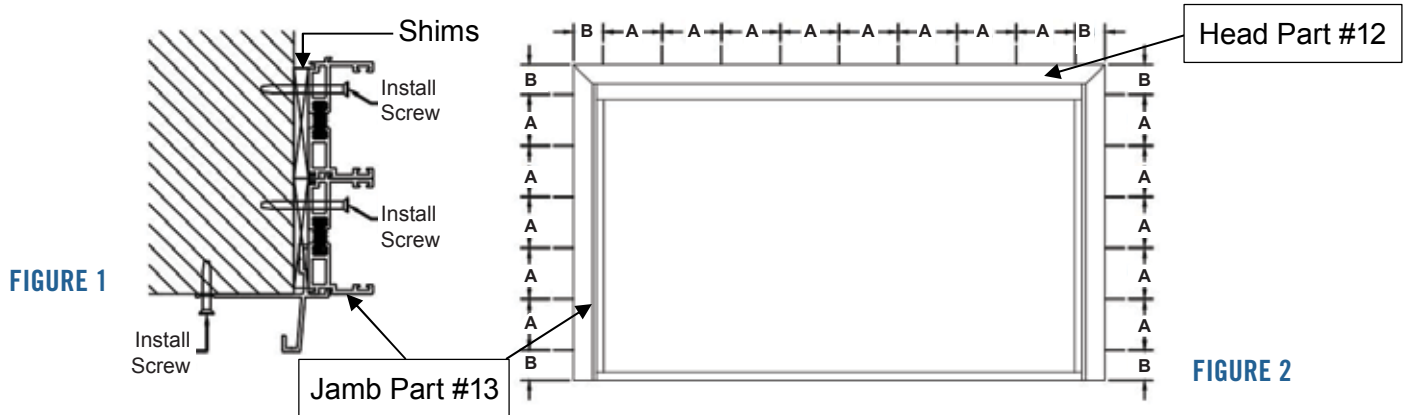

FIGURE 2

14. Apply backer rod and compatible sealant to the interior joint between the frame and the rough opening as shown in Figures 1 & 2.

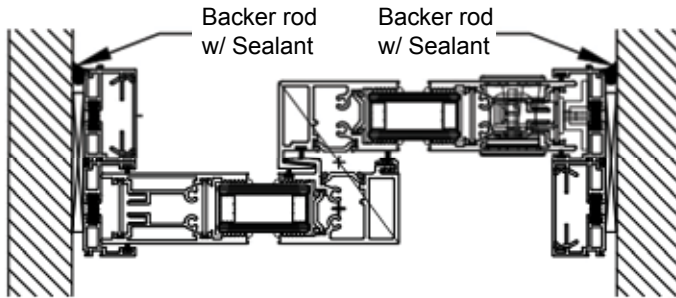

FIGURE 1

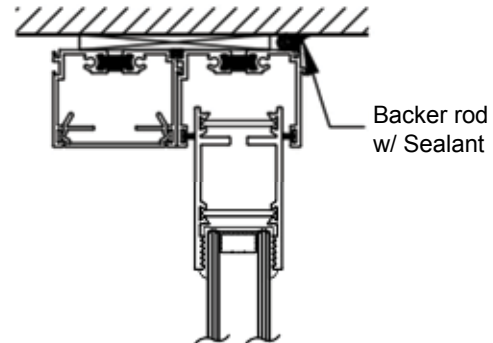

FIGURE 2

PANEL INSTALLATION

Before installing panels, make sure the fixed panel holders are in the right place. Note that standard and flush set sills (Part #14a, 14b) have different fixed panel holders. For a standard sill, the fixed panel holders should be in the sill prior to panel installation (Figure 1). For a flush set sill, the fixed panel holder should be attached to the bottom of the fixed panel first, to be installed later with the panel (Figure 2).

Standard Sill Fixed Panel Holders

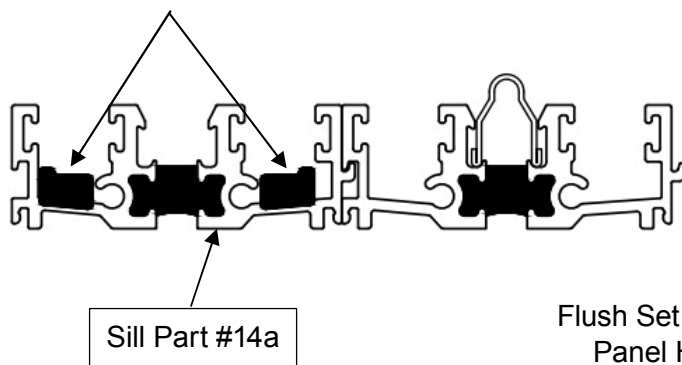

FIGURE 1

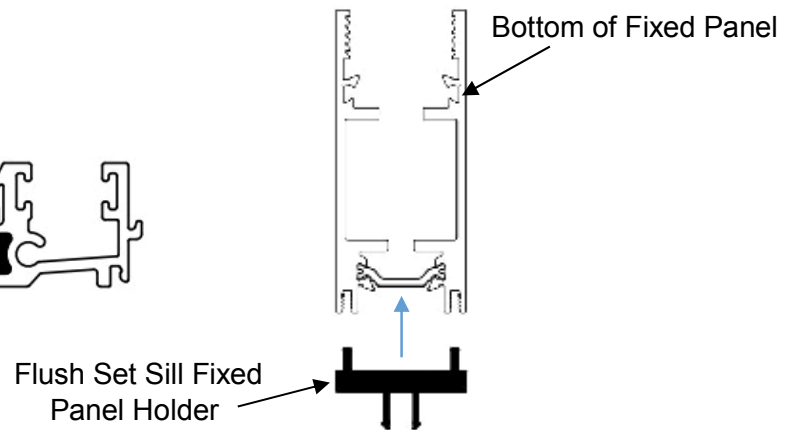

FIGURE 2

15. Install the sliding panel into the interior frame track. You may use a putty knife or similar thereof to help lift the rollers over the tracks. If you have a staggered track door, you will need to temporarily remove the head and sill track end caps (Part #19, #20) to avoid clearance issues. For info on removing and installing staggered track end caps, consult Appendix A. If installing an OXXO door, install both sliding panels on the interior track. If installing an OXX or XXO door, install the locking panel to the interior track and the additional rolling panel in the center track as shown in Figures 1 and 2.

OXXO

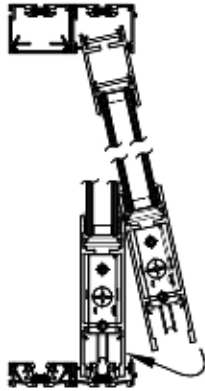

FIGURE 1

OXX/XXO

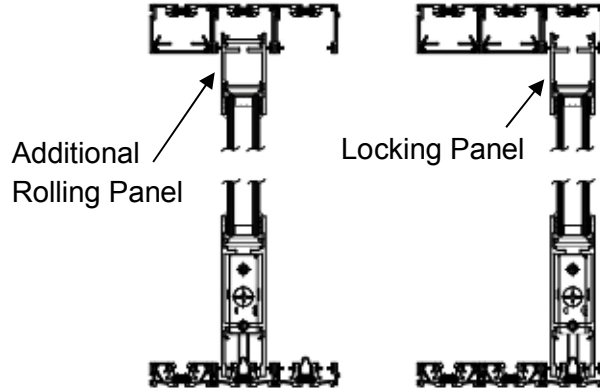

FIGURE 2

16. Temporarily adjust the panel upward by lifting the panel and turning the adjustment screw shown in Figure 1 clockwise as shown in Figure 2 until the rollers regain contact with the track. It is important to physically lift the panel while adjusting upward so that the adjustment screw does not strip due to the weight of the panel. Adjust the rollers of the active panels by turning the adjustment screw shown in Figure 1 to achieve proper alignment of the door panels (it is easier to adjust down than up). Turn screw clockwise to raise the panel and counterclockwise to lower the panel as shown in Figure 2.

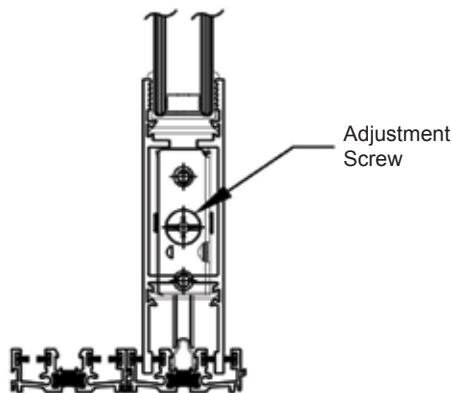

FIGURE 1

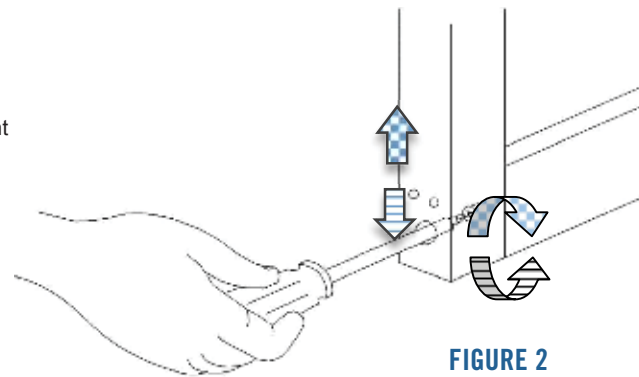

FIGURE 2

17. Install the fixed panel into the exterior jamb track (Part #13). Secure fixed panel to the frame with the 2 screws (Part #3) provided in the hardware box (use sealant to lubricate screws). Screw through the pre-drilled holes in the center weather strip track of the jamb at 24" above the sill and 24" below the head as shown in Figures 1 & 2.

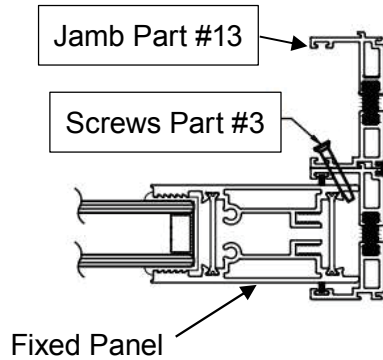

FIGURE 1

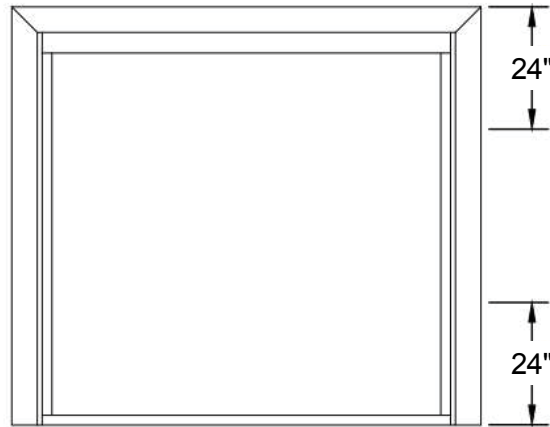

FIGURE 2

KEEPER INSTALLATION

18. After the final roller adjustments, install the keeper(s) (Part #15) into the lock side jamb (Part #13) by aligning with the lockset hooks on the panel and marking the location of the keeper's four screw holes onto the jamb. Next, pre-drill holes in the jamb at the marked locations using a $\frac{1}{8}$ " - $\frac{3}{16}$ " drill bit. Lastly, fasten the keeper to the jamb with screws (Part #1) as shown in Figure 1 (use sealant to lubricate screws). After the keeper has been installed, adjust the throw on the hooks of the lockset to ensure a tight fit when the door is closed and locked by turning the adjustment screw located between the hooks shown in Figure 2.

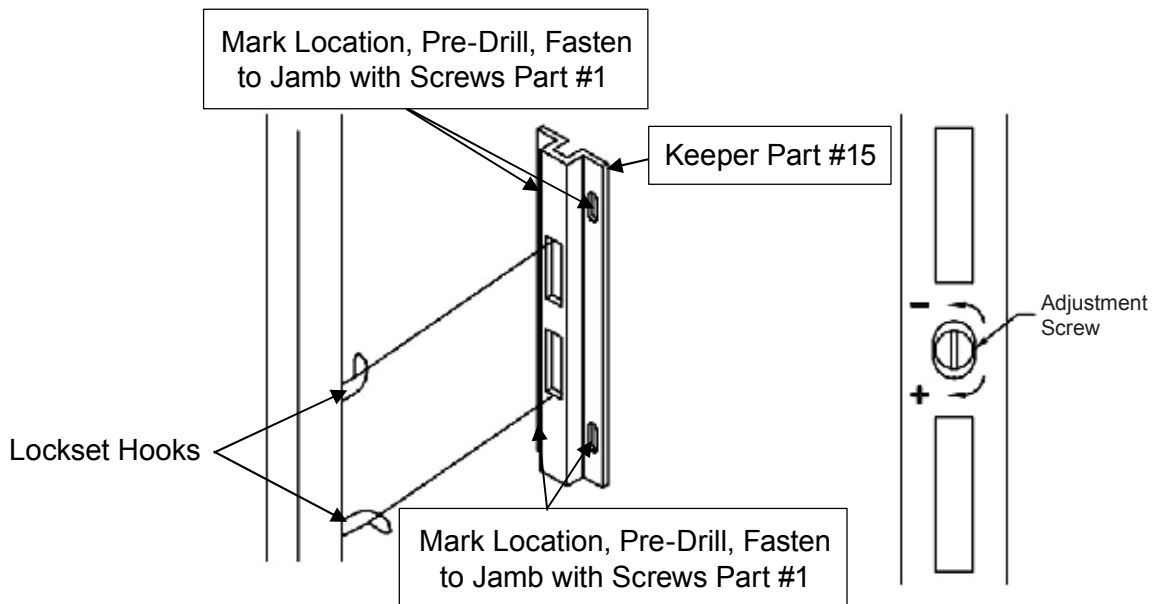

FIGURE 1

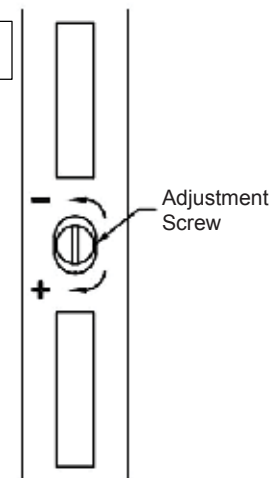

FIGURE 2



TRIM CAP AND THRESHOLD RE-INSTALLATION

FOR OX, XO, OXO, AND XOX DOORS FOLLOW STEPS 19-20.

19. Take the longest trim cap pieces (Part #16) and install into the exterior jamb track (Part #13) of the operable side shown in Figure 1 and interior jamb track of the fixed side as shown in Figure 2.

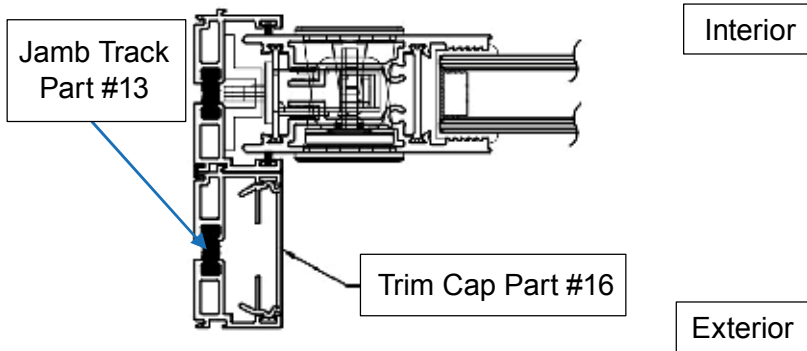

FIGURE 1

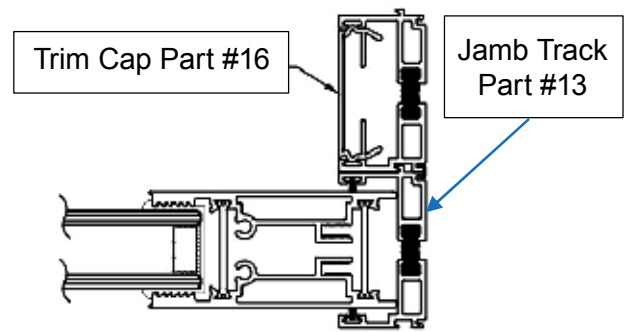

FIGURE 2

20. Install the threshold (Part #17) into the exterior sill track (Part #14a) and install the smallest trim cap (Part #16) into the head exterior track (Part #12) shown in Figures 1 & 2

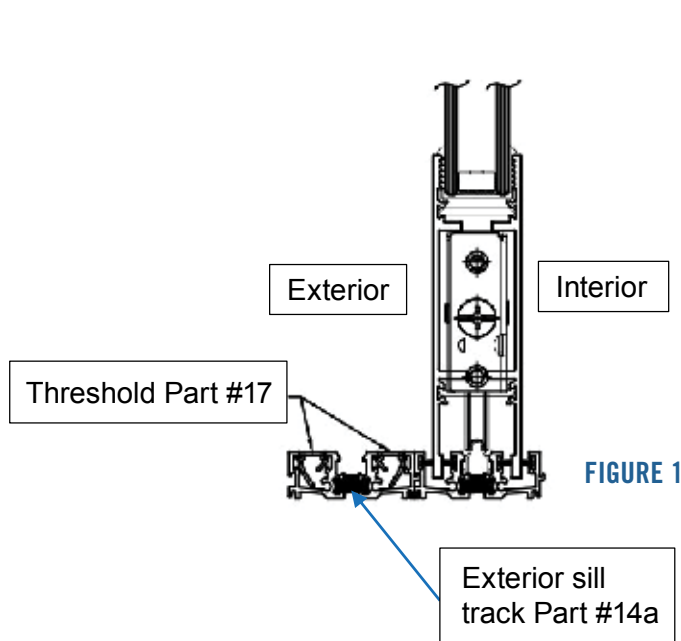

FIGURE 1

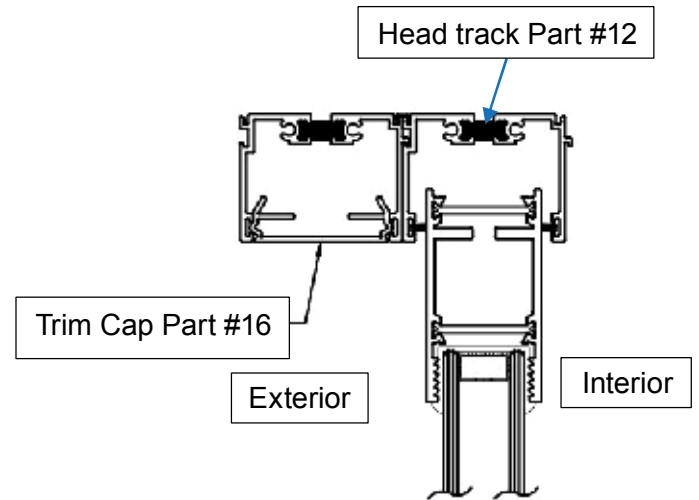
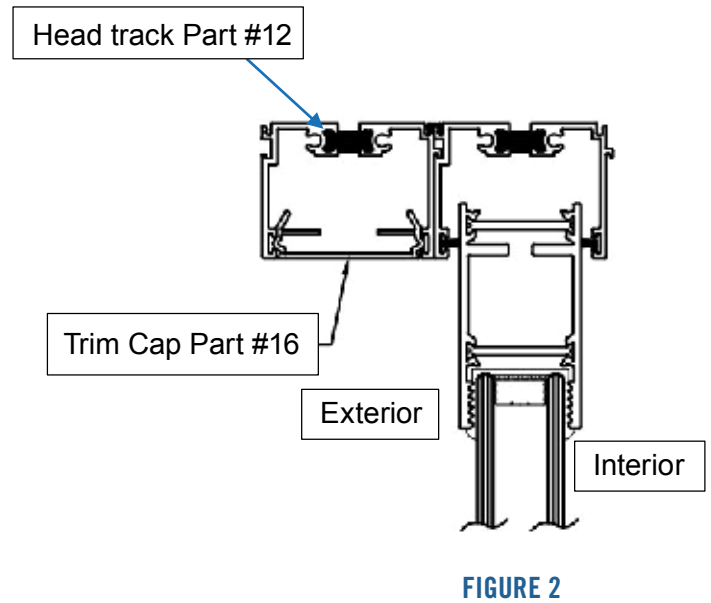
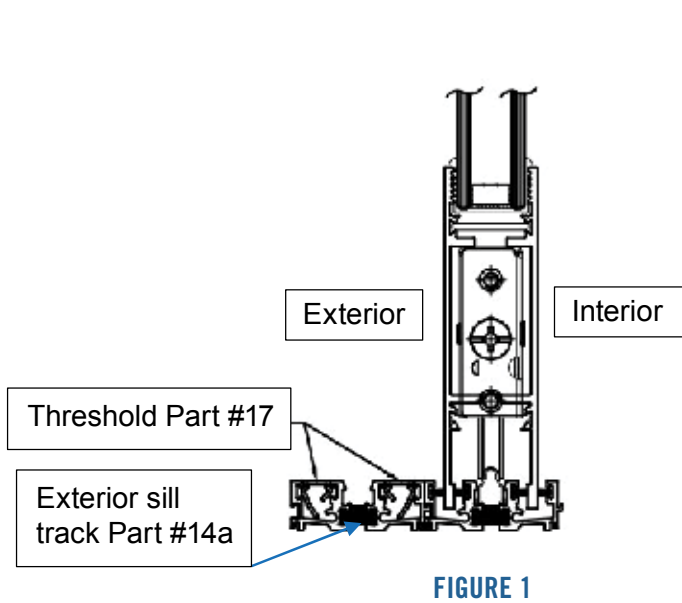

FIGURE 2



FOR OXO DOORS FOLLOW STEPS 21-22.

21. Install thresholds (Part #17) into the exterior sill track (Part #14a) shown in Figure 1 then install the trim cap (Part #16) that is the same length as the threshold into the exterior head track (Part #12) shown in Figure 2.



22. Install the remaining trim caps (Part #16) into the interior jamb tracks shown in Figures 1 & 2.

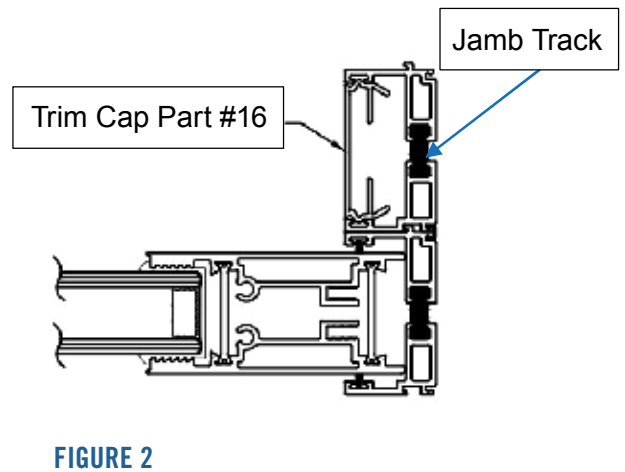
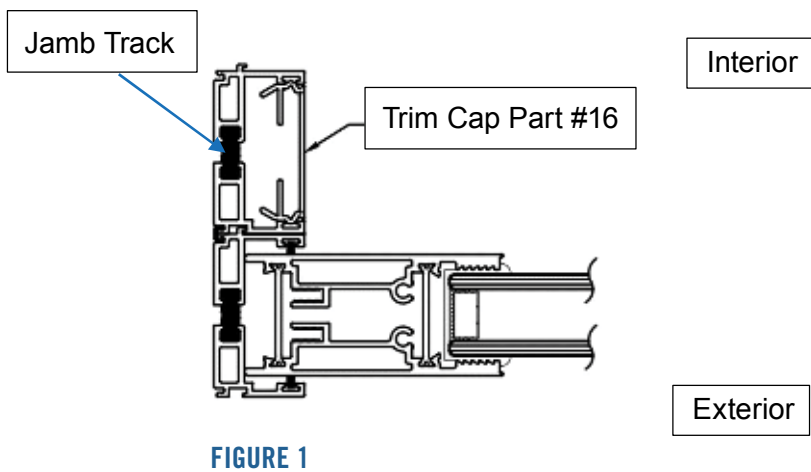

FOR OXX OR XXO DOOR FOLLOW STEPS 23-24.

23. Install the longest trim cap pieces (Part #16) into the exterior and center jamb tracks (Part #13) on the operable side as shown in Figure 1 then install the other two trim caps that are the same length into the interior and center jamb tracks shown in Figure 2.

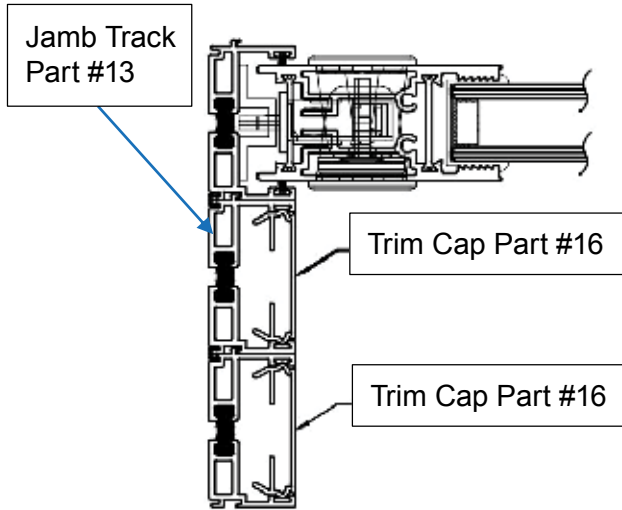

FIGURE 1

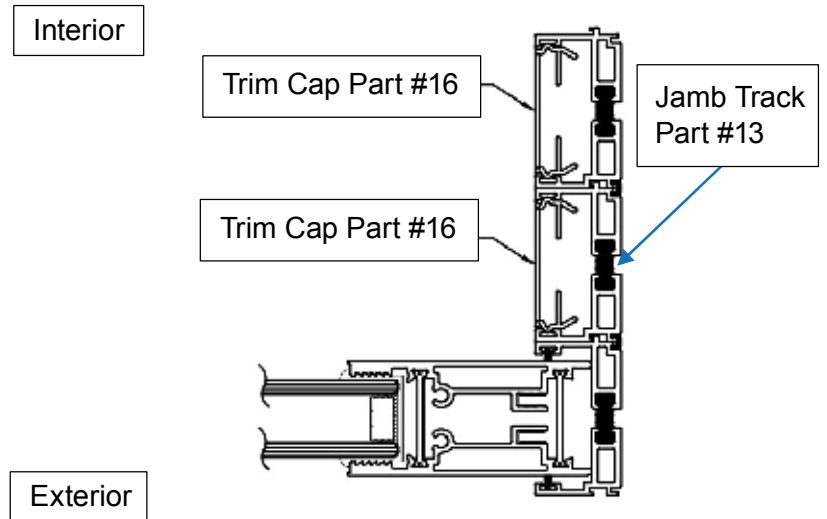

FIGURE 2

24. Install thresholds (Part #17) into the exterior and center sill tracks (Part #14a) shown in Figure 1 and the trim cap (Part # 16) of the same length into the exterior and center head tracks (Part #12) shown in Figure 2.

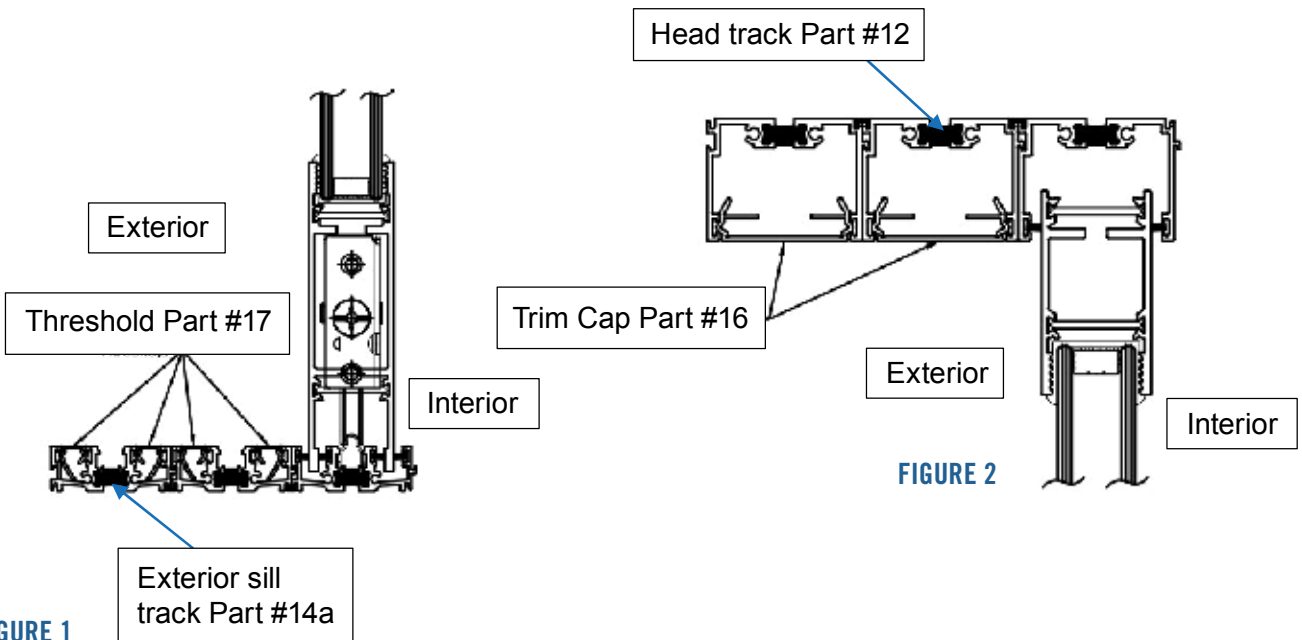

FIGURE 1

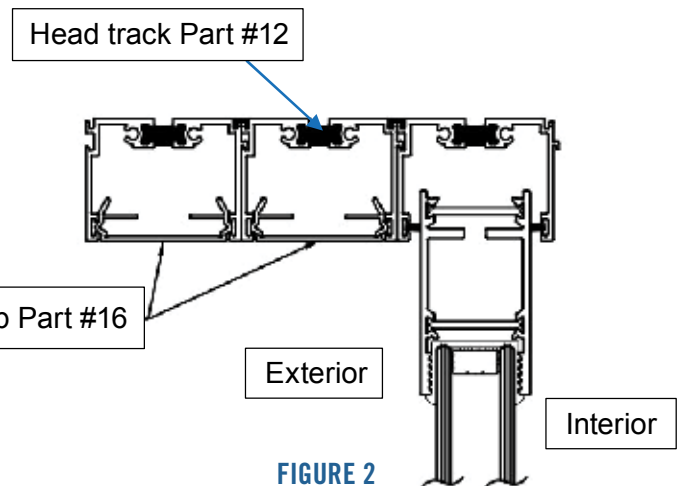

FIGURE 2



PULL HANDLE INSTALLATION

25. Install the pull handle (Part #21a, 21b, or 21c) by inserting the exterior and interior handle into the pre-drilled holes. Secure handle by installing the screws included with the handle kit on the interior side as shown in Figure 1.

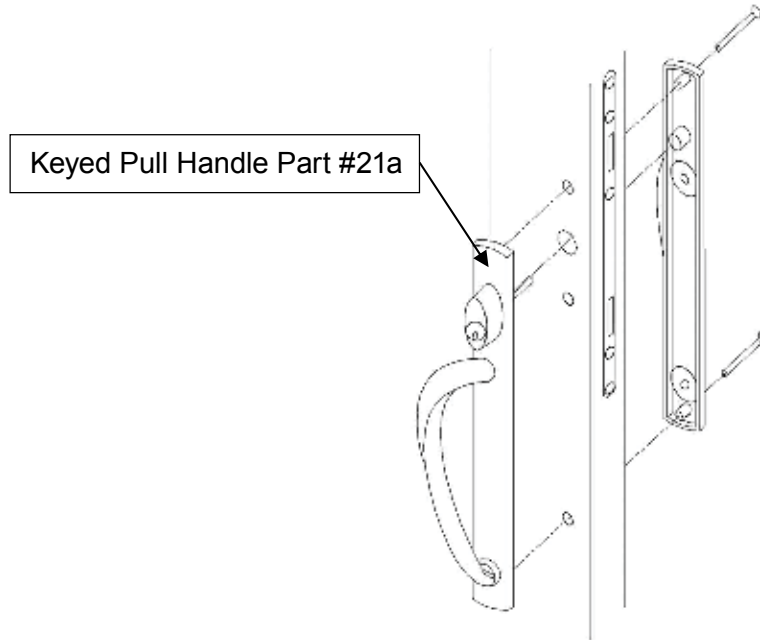

FIGURE 1

PANEL COLLECTOR INSTALLATION

26. Install panel collector (Part #18) on the first intermediate panel using the pre-drilled holes and Part #5 screws as shown in Figure 1. If more than one panel collector is necessary for your configuration (4 panels or more), install remaining panel collectors one at a time ensuring proper alignment as shown in Figure 2.

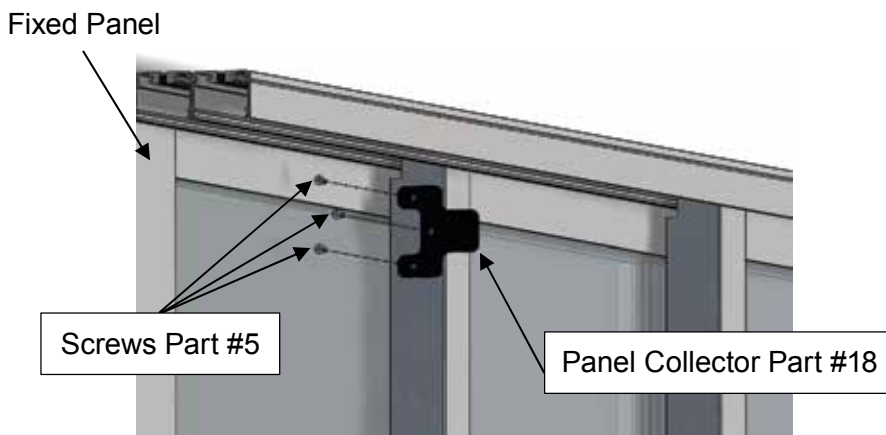

FIGURE 1

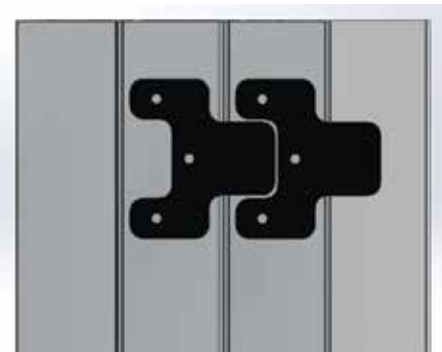

FIGURE 2



APPENDIX A:

TRACK END CAP REMOVAL AND INSTALLATION (FOR STAGGERED TRACK DOORS ONLY)

For staggered track doors only, assemblies come with sill and head track end caps attached (Part #19, #20). These are designed for aesthetic purposes to cover the exposed head and sill track faces in the location the staggered tracks terminate. To remove the end caps for panel installation, simply unscrew the screws (Part #5) from the head or sill screw channels and remove the caps. When reattaching after panel installation, the track faces should be coated in sealant, and the end cap screwed back onto the face via screw channels as shown in Figures 1 & 2.

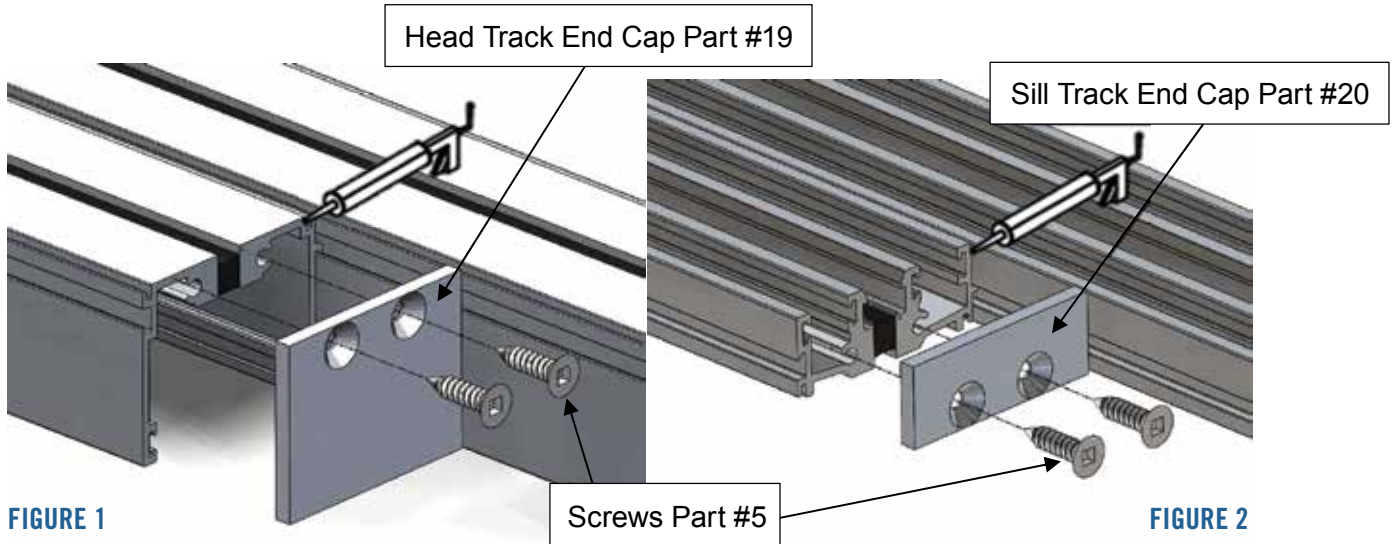



APPENDIX B:

BRIO SCREEN SECTION DETAIL

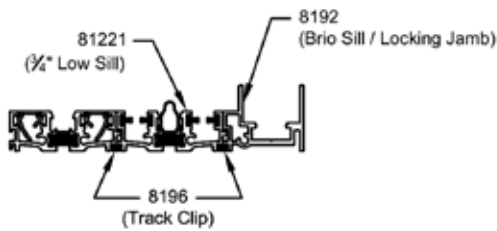
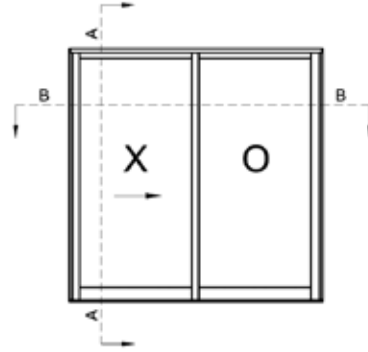
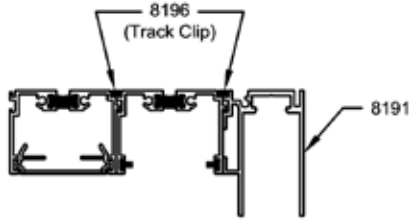

FOR 3/4" LOW SILL (81221)

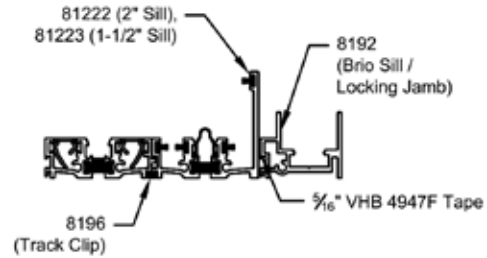

FOR WATER LEG SILLS (81222, 81223)

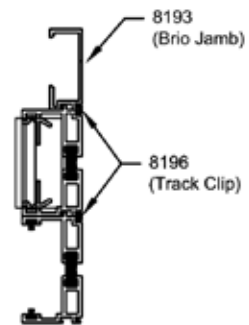
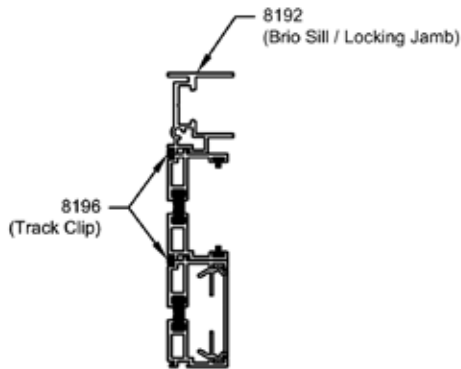

*XO configuration shown for reference



APPENDIX C:

BRIO SCREEN INSTALLATION



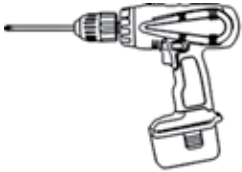







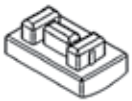
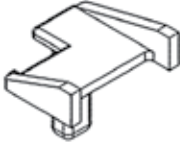
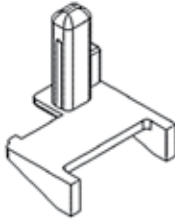



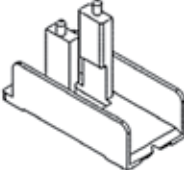

RECOMMENDED TOOLS



PRE-INSTALLATION NOTES

1. Install the screen after the frame and panels are installed properly.
2. The screen will always be installed on the interior side.
3. Screens are not handed.

SCREEN KIT

	x2		x1		x1		x2												
WS-MS-3 MESH SUPPORT		WS-PK-T TOP PACKING BLOCK		WS-PK-B BOTTOM PACKING BLOCK		WS-CS COMPRESSION SPRING													
	x2		x2		x1		x2												
WS-GR-2 HANDLE GRIP		WS-AB-A ADJUSTMENT BLOCK ASSEMBLY		WS-FB-3 FRICTION BLOCK		WS-CEIN CASSETTE EXTRUSION RETAINER CLIP													
	x1		x2	<p>Components used for a double screen only</p> <table border="0"> <tr> <td></td> <td>x3</td> <td></td> <td>x9</td> <td></td> <td>x1</td> </tr> <tr> <td>WS-MP MAGNET PLATE</td> <td></td> <td>SC3GX7S 3G X 7 CSK SCREW SS</td> <td></td> <td>WS-MST MAGNETIC STRIP</td> <td></td> </tr> </table>					x3		x9		x1	WS-MP MAGNET PLATE		SC3GX7S 3G X 7 CSK SCREW SS		WS-MST MAGNETIC STRIP	
	x3		x9		x1														
WS-MP MAGNET PLATE		SC3GX7S 3G X 7 CSK SCREW SS		WS-MST MAGNETIC STRIP															
WS-AK ALLEN KEY		TEKS-62020CX 20X6-20 CSK TEK SCREW																	

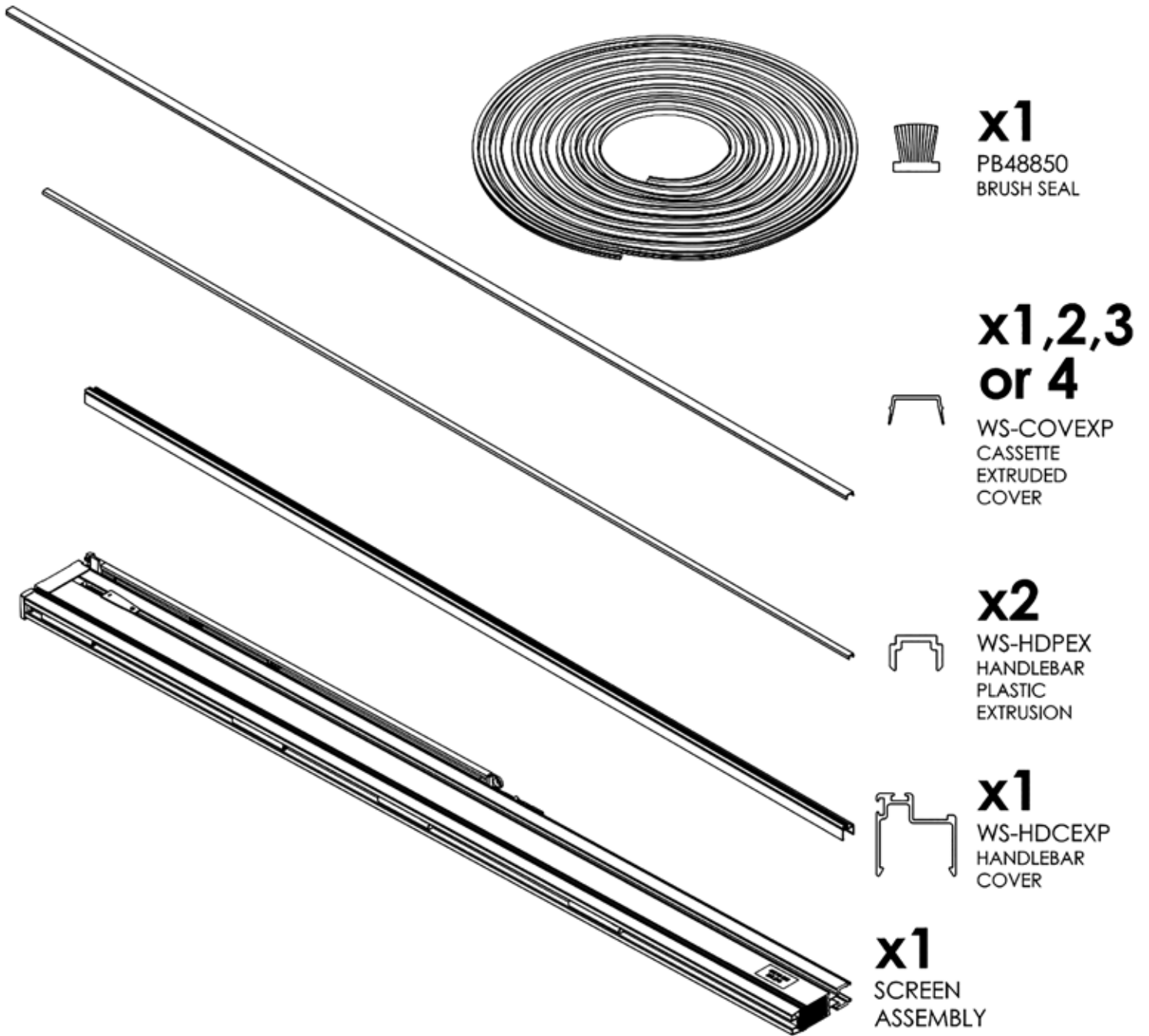

HARDWARE INSTALLATION

1. Insert the handle

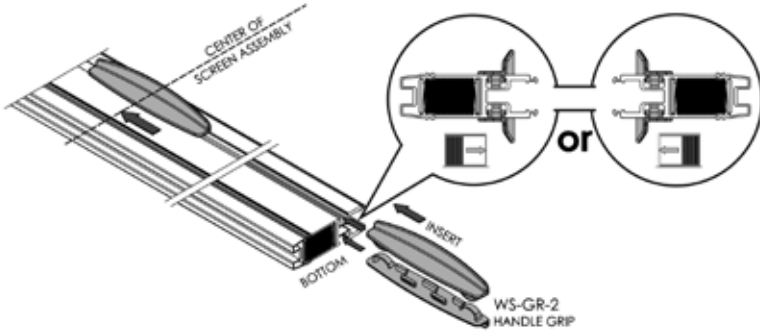

3. Insert the adjustment block

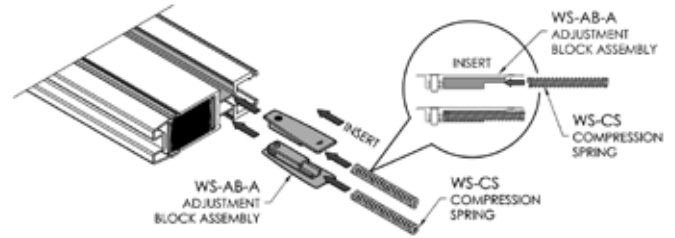

2. Insert the friction block

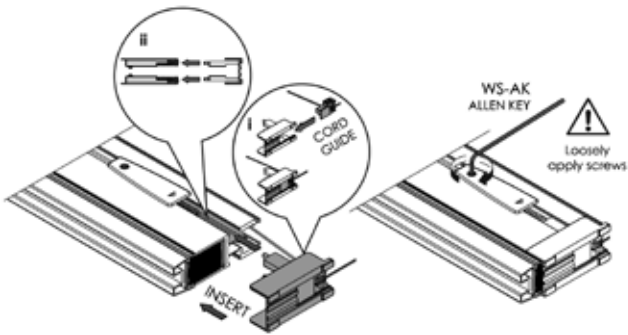

4. Insert the mesh retainer

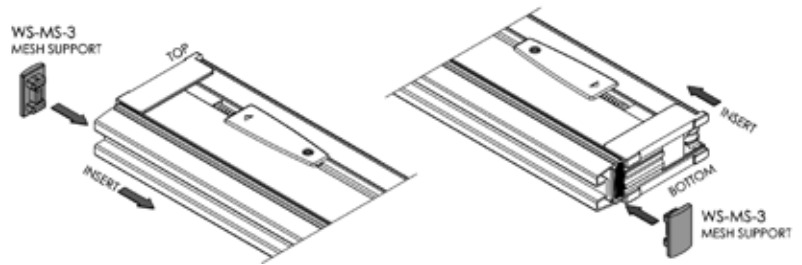

SCREEN INSTALLATION

1. Remove the plastic wrapping. Wrap the screen assembly with tape while keeping it tightly compressed.

! Carefully remove wrapping. Ensure that the screen assembly is tightly compressed

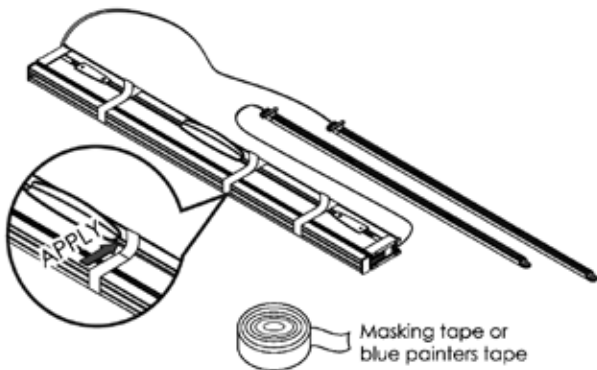

2. Insert the assembly into the sill track at an angle. Raise the assembly into an upright position then slide it into the jamb until it snaps in place.

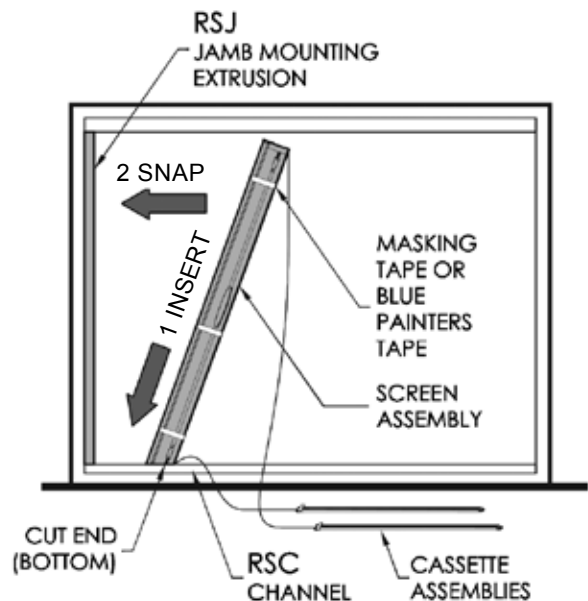



3. Align the cords. Start from the individual rollers, then align the cords on the end rollers.

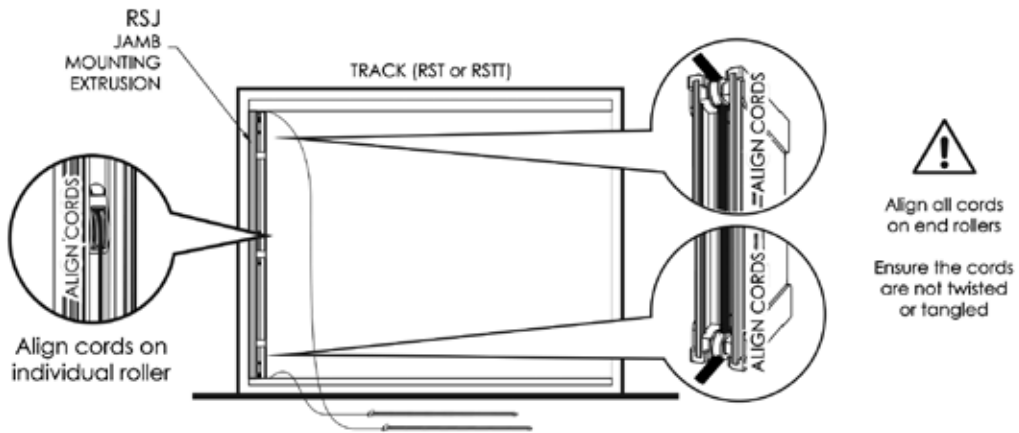

4. Begin the cassette assembling process. The A side points toward the locking jamb side. Start with the bottom cassette.

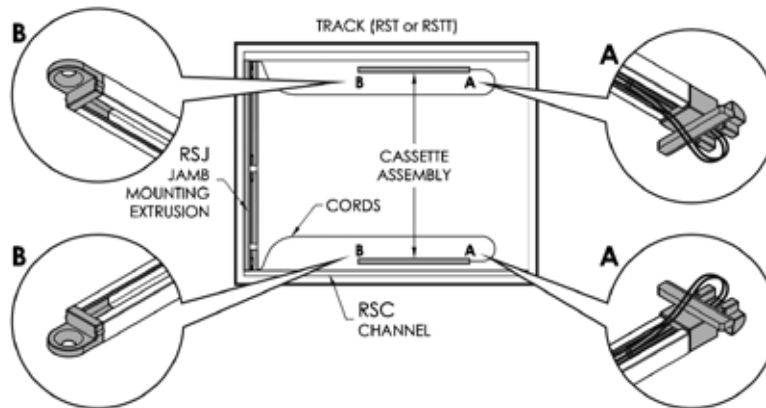

FITTING BOTTOM CHANNEL CASSETTE

1. Insert the A side of the cassette into the bottom channel.
2. Rotate the cassette 90 degrees inward.
3. Pivot the cassette onto its back so that it is laid onto the sill track, then slide the cassette into the locking jamb side.
4. Insert the Phillips head screw into the hole on the B side of the cassette.

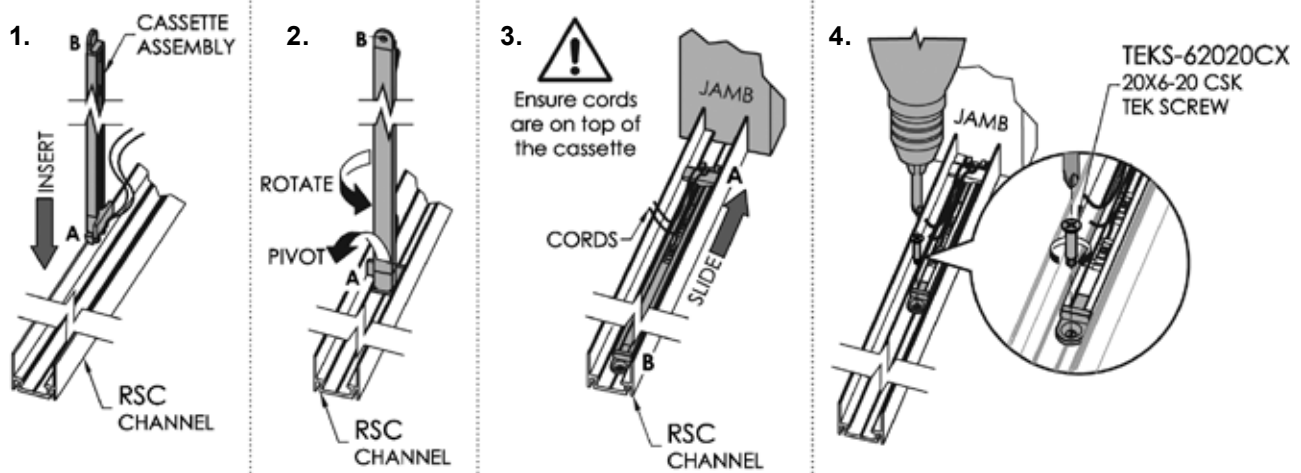

FITTING TOP TRACK CASSETTE

The top cassette is installed in the same way as the bottom, except for using the retainer(s) before installation.

Fit WS-CEIN - cassette retainer before fitting cassette into the top track (RST or RSTI)

- <144 (3657) x1 per cassette assembly
- >144 (3657) x2 per cassette assembly

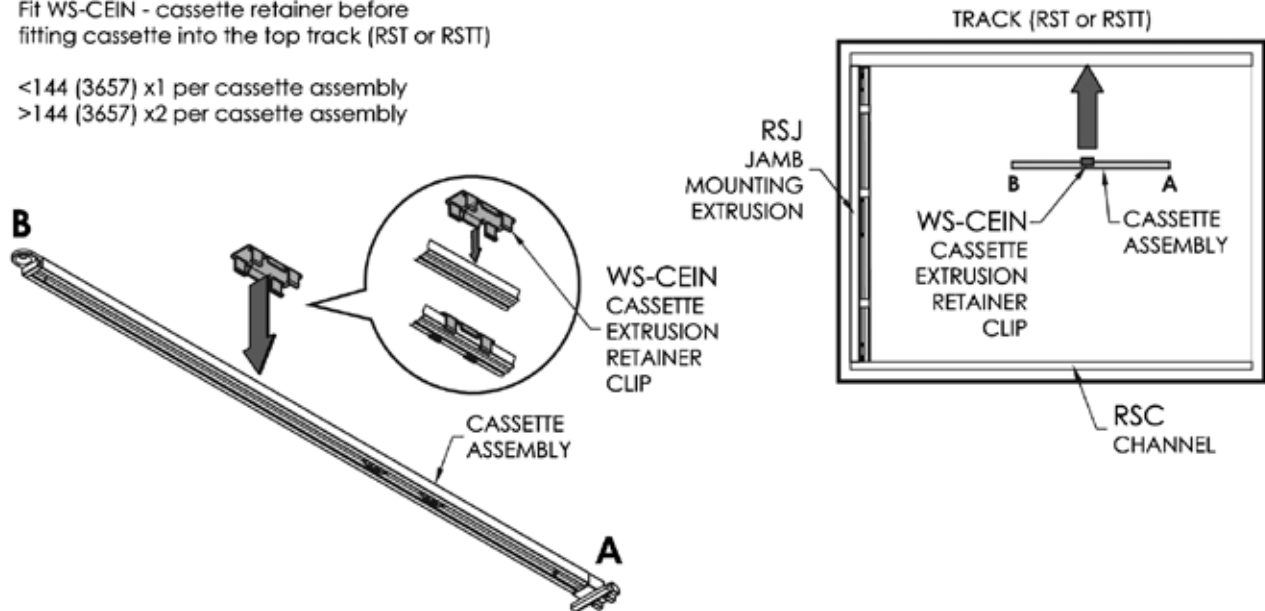

CORD TENSIONING



Ensure that the screen assembly is tightly compressed. Slide cord anchors to take up the slack and stretch a further $\frac{9}{16}$ (15). Remove tape and operate screen to confirm smooth operation (screen will not extend fully until handle bar cover is installed).

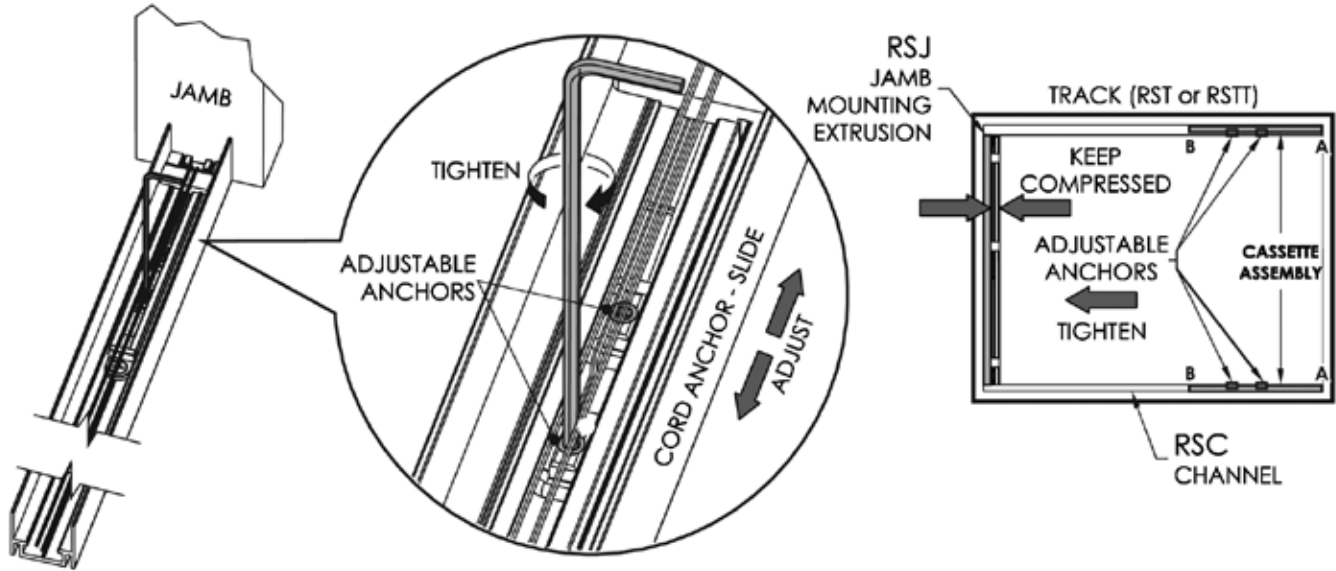

PREPARING THE HANDLEBAR COVER

*See pages 38-39 for double screen

1. Cut the handlebar cover to length

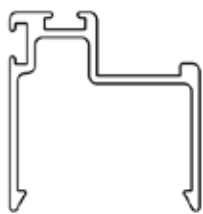

WS-HDCEXP
HANDLEBAR
COVER

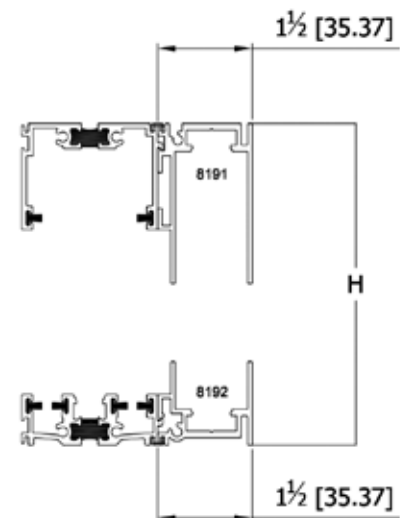
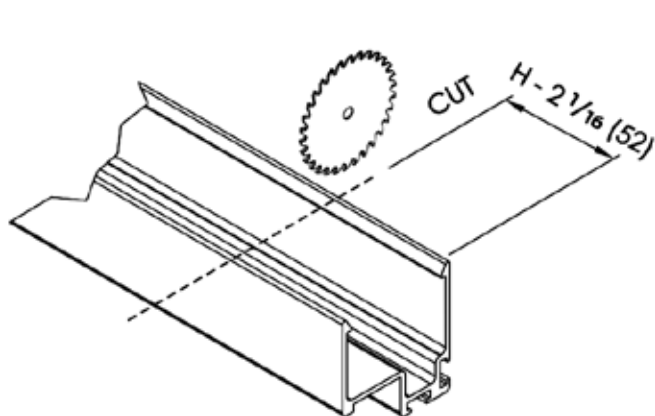

2. Install weatherstrip

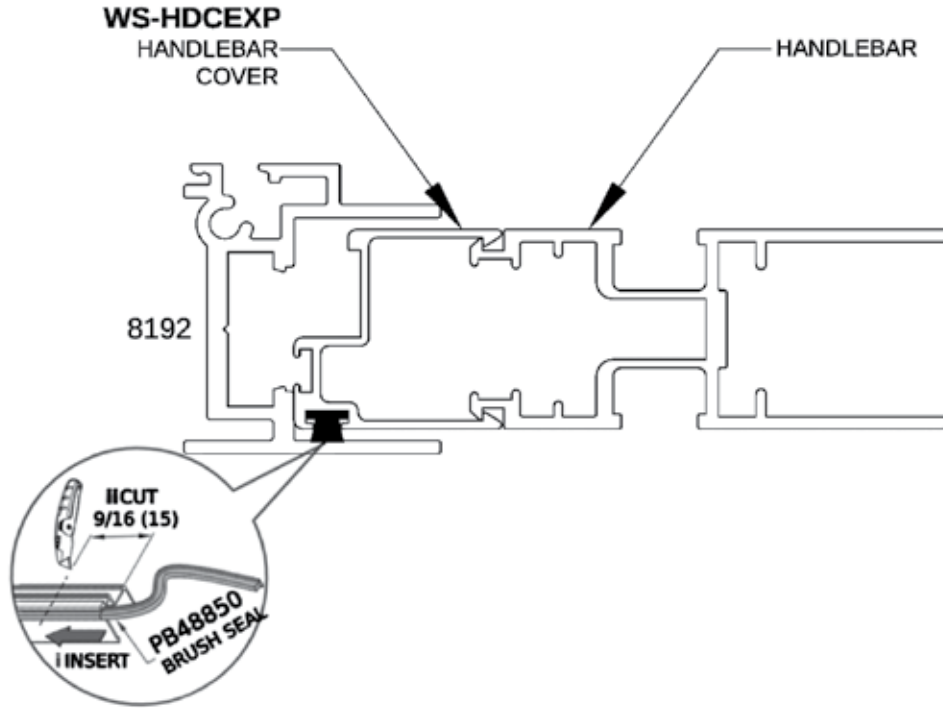

3. Insert packing blocks



FITTING THE HANDLEBAR COVER

Remove the tape from the screen assembly. Angle the handlebar cover (bottom first) until it snaps in.

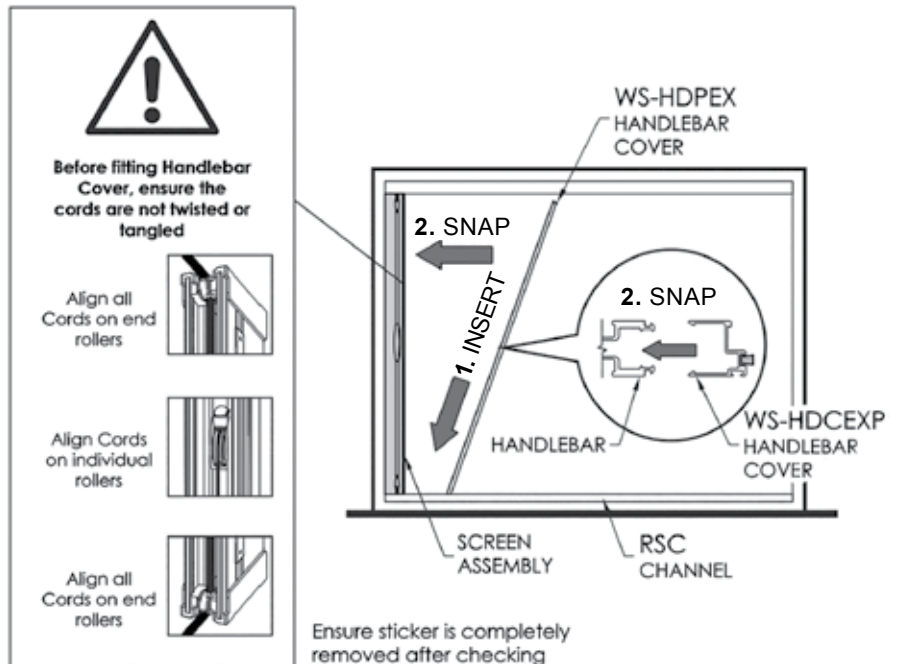



ADJUSTING THE HANDLEBAR COVER

If there is a gap at the top, increase the tension at the top and release the tension at the bottom. If the gap is at the bottom, release the tension at the top and increase the tension at the bottom.

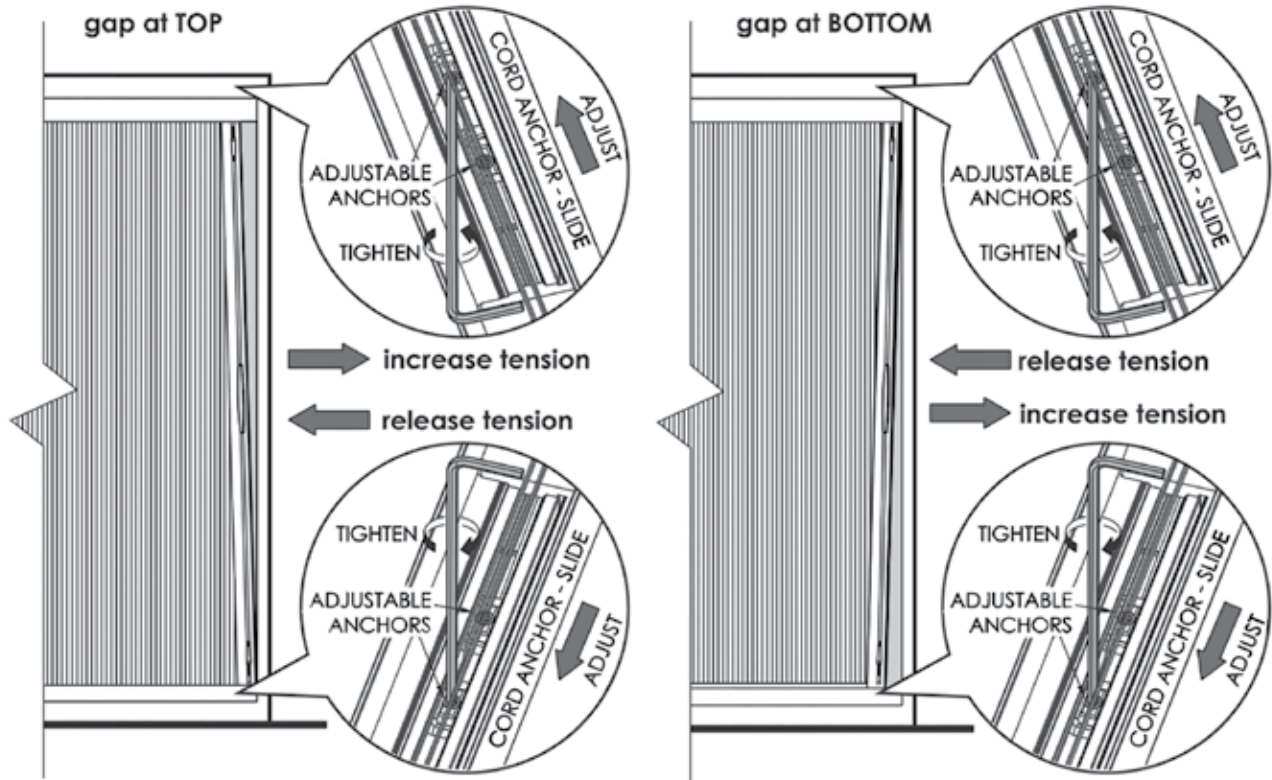

SCREEN ADJUSTMENT

To raise or lower the entire screen, tighten or loosen the springs (part WS-CS) at the top and bottom of the screen that were installed at the beginning (page 30, under **Hardware Installation**).

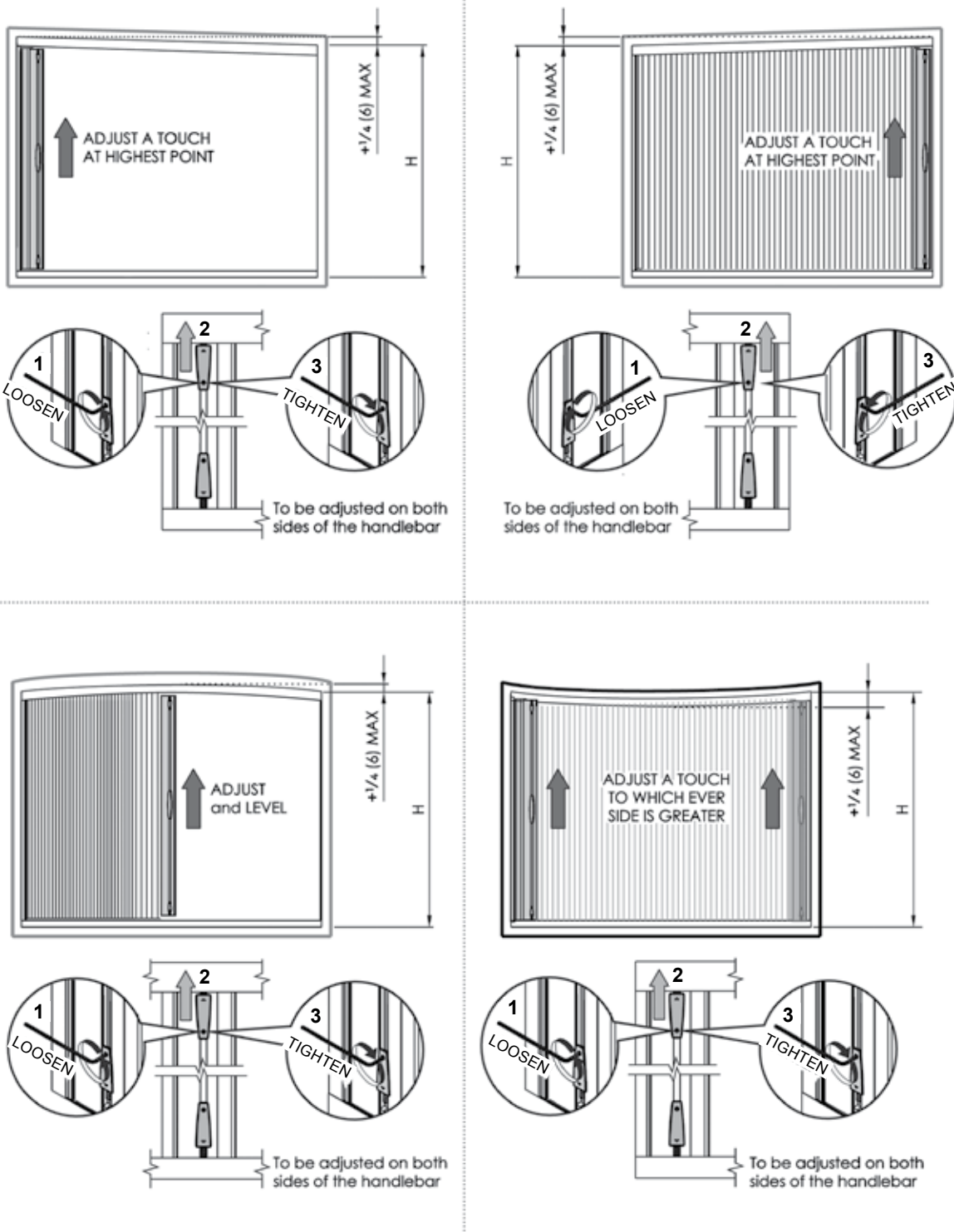



COMMISSIONING

1. Ensure channel (RSC) is free from dirt and debris.
2. Ensure screen slides freely from side to side.
3. Ensure screen meets at the jamb or meeting screen (double or corner applications) without any gaps.
4. Once screen is operating correctly, fit the remaining components (as shown below).

FITTING CHANNEL COVERS

Position the channel covers beneath the cords. Lift the handlebar, then squeeze the cover and snap it in the bottom channel. Make sure the cords are on top of the cover, then slide the cover underneath the handlebar.

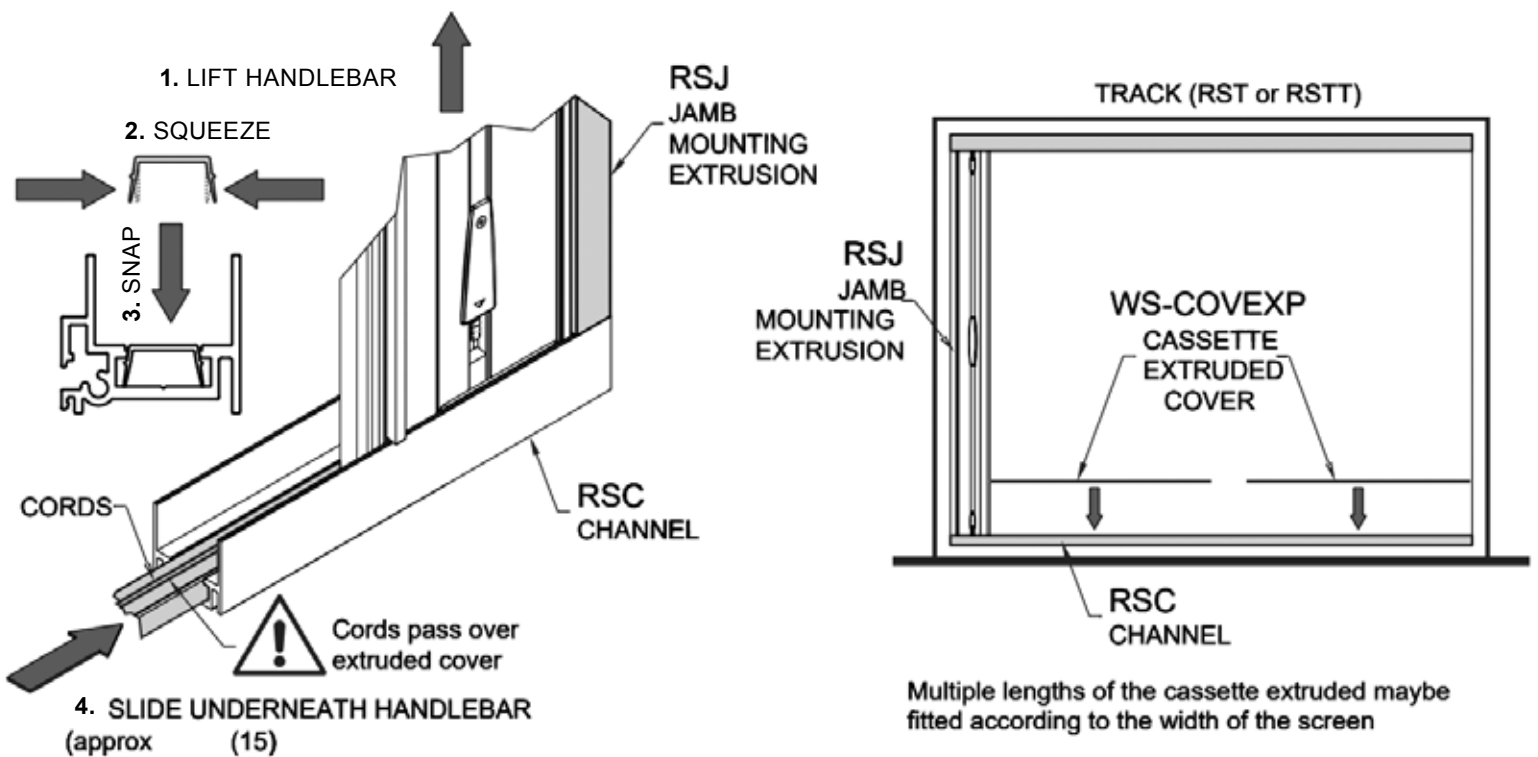

FITTING HANDLEBAR TRIM

Measure the lengths between the handlebar and the spring adjustment pieces at the top and bottom respectively, then add 3/8" to your measurements and cut the trim. Squeeze the trim and insert it into the channel. Repeat this process with the other side. Your screen installation is now complete.

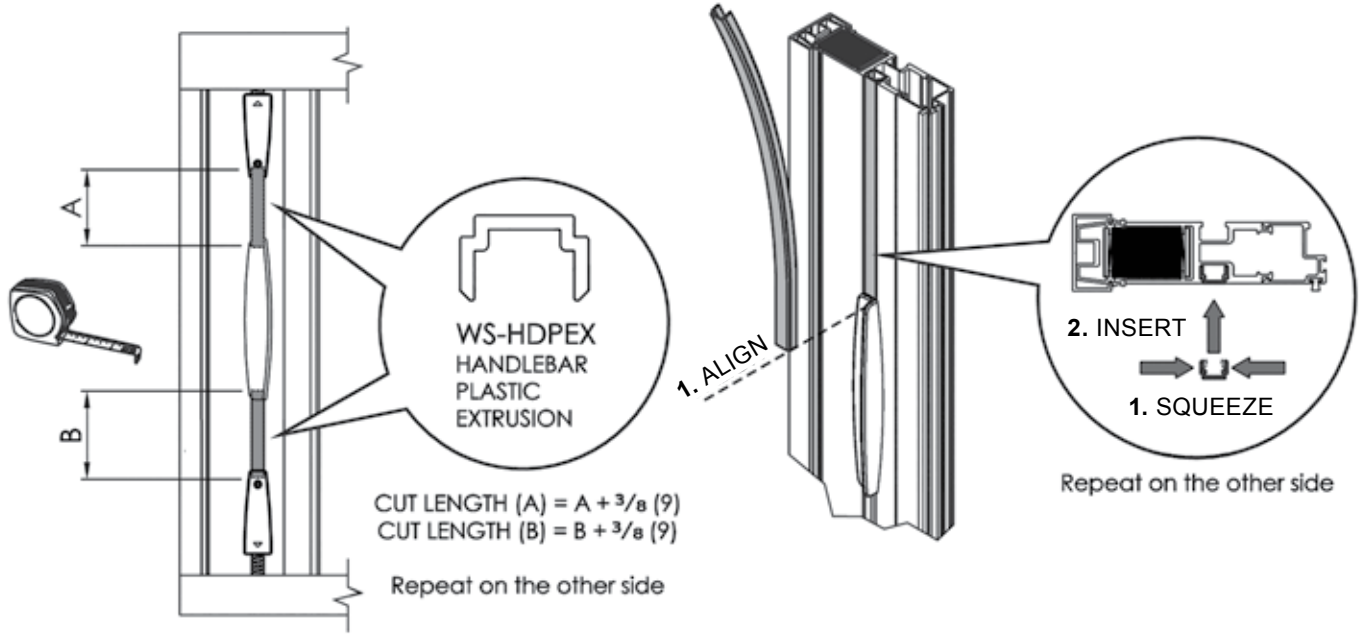

FITTING CASSETTES FOR DOUBLE SCREENS (FOR BI-PARTING DOORS ONLY)

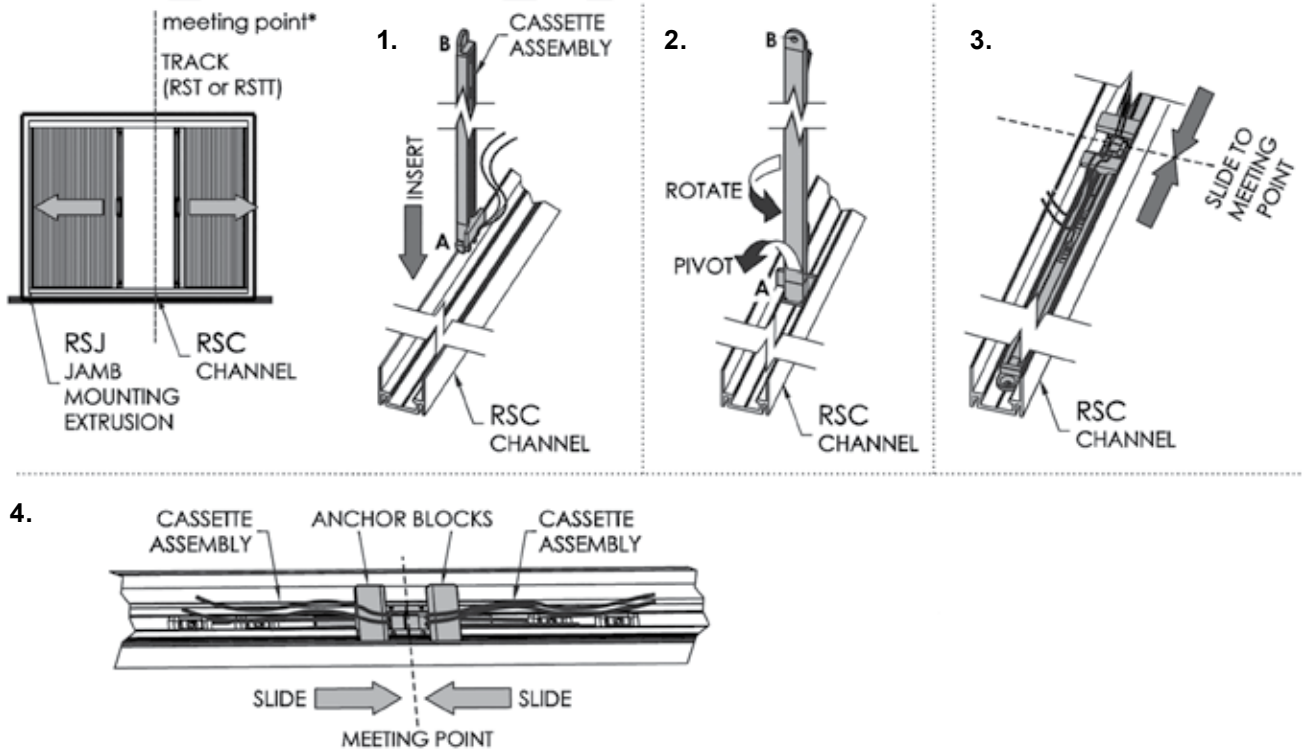



FITTING MAGNET AND MAGNET PLATES FOR DOUBLE SCREENS (FOR BI-PARTING DOORS ONLY)

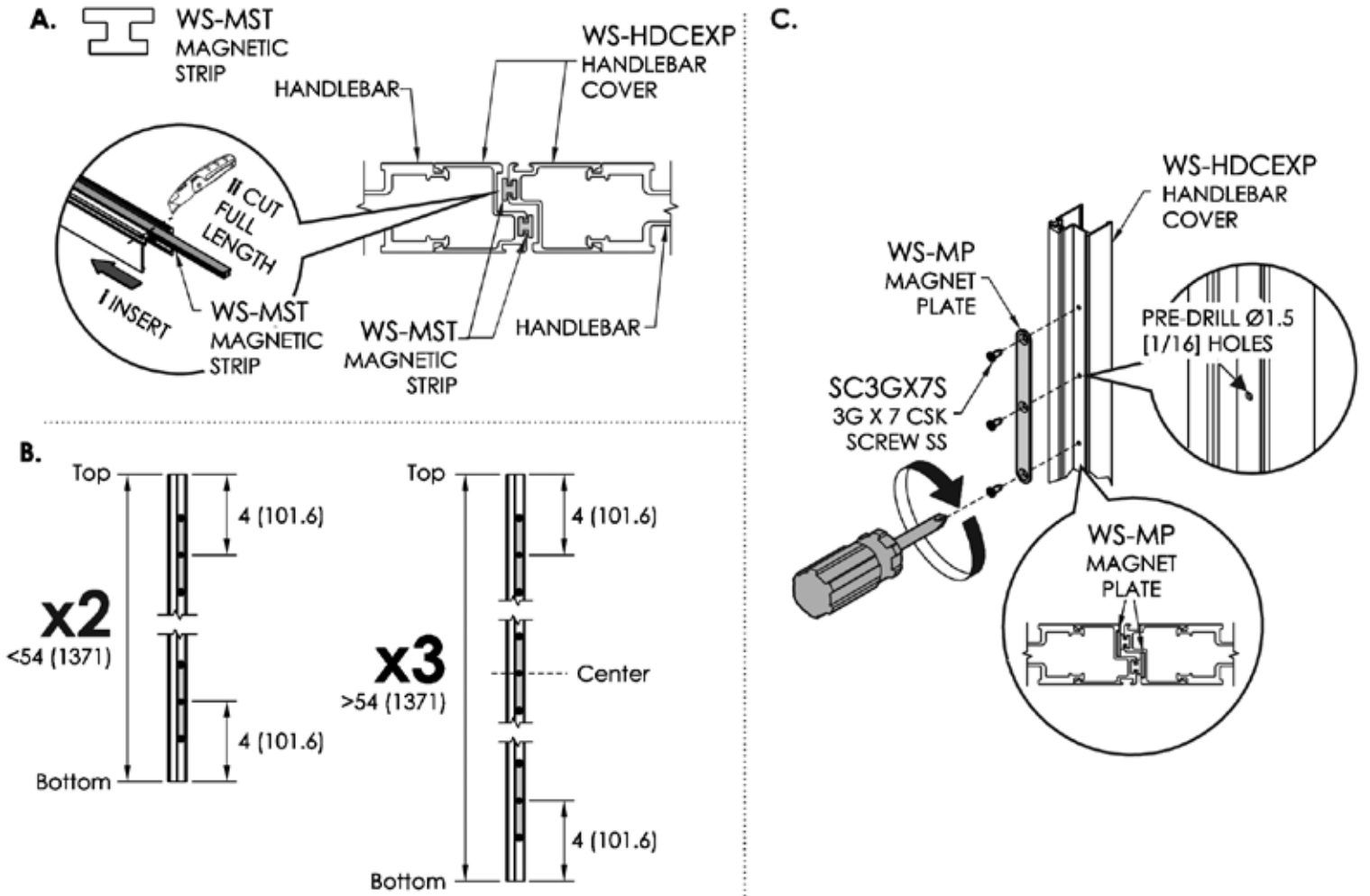



APPENDIX D:

BRIO SCREEN REPLACEMENT

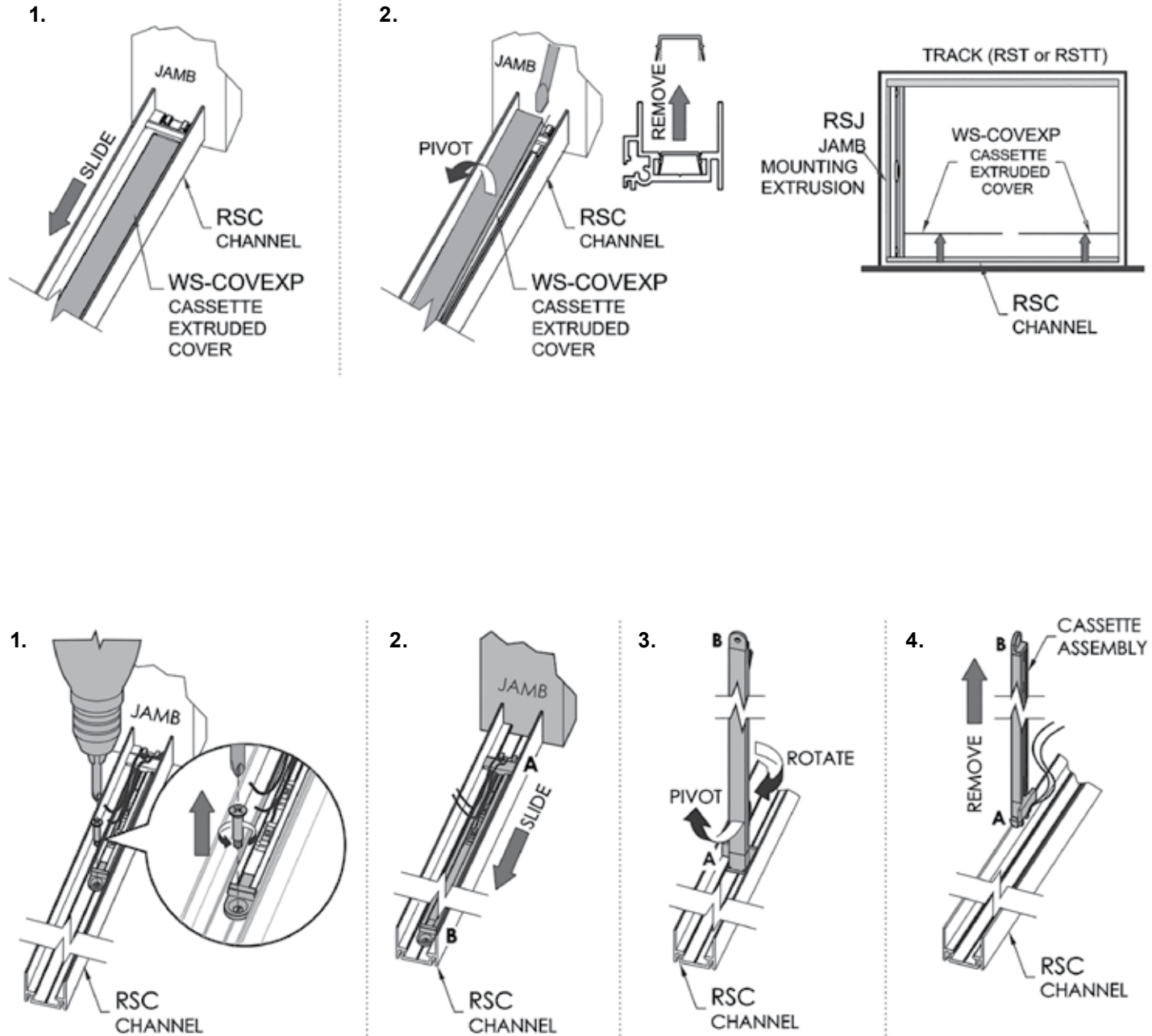



REMOVE SCREEN ASSEMBLY

1. SQUEEZE USING PLIERS

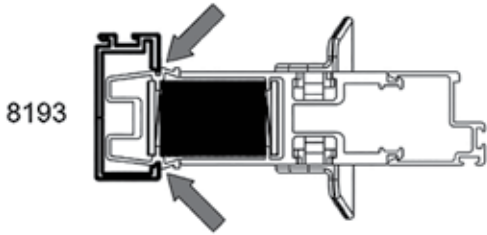

Use pliers with masking tape to protect the surface

2. REMOVE

